

# HUST CNC

## BENDING MACHINE

OPERATION MANUAL

【H4B 3-AXIS】

2005-09

# Contents :

一、 Non Mode Page .....	1
二、 AUTO mode : (main page) .....	3
三、 File setting page .....	7
四、 Editing mode .....	10
五、 MCM ( Vice ) setting page .....	11
六、 Type setting page .....	12
七、 Bending-selection for fold setting page .....	13
八、 JOG mode .....	15
九、 HOME mode .....	18
十、 Error and Absolve .....	19
十一、 Bending Machine I/O List .....	21
十二、 Machine Connection Diagram .....	23
Appendix -1、 Emergent Stop Connection Diagram .....	26
Appendix -2、 Servo Driver Servo-On Connection Diagram .....	27
Appendix- 3、 H4B Controller size .....	28
Appendix- 4、 Bending Angle Conception .....	29
Appendix -5、 H4B Control Structure of Bending Machine .....	30
Appendix- 6、 MCM (Parameter) .....	31
Appendix- 7、 Sanyo Servo Machinery Connection .....	44
Appendix- 8、 Mitsubishi Servo Machinery Connection .....	45
Appendix- 9、 Servo Motor And MPG Connection .....	46

<b>Appendix- 10、 Install Manual</b> .....	<b>47</b>
H4B LCD flow-process diagram .....	<b>52</b>
<b>Appendix- 11、 ERROR MESSAGES</b> .....	<b>53</b>

**When the controller is power on it will download some data. So do not operate the controller till the download operation finished.**



## 一、 Non Mode Page

---



To main page : Press “AUTO” on the key board.

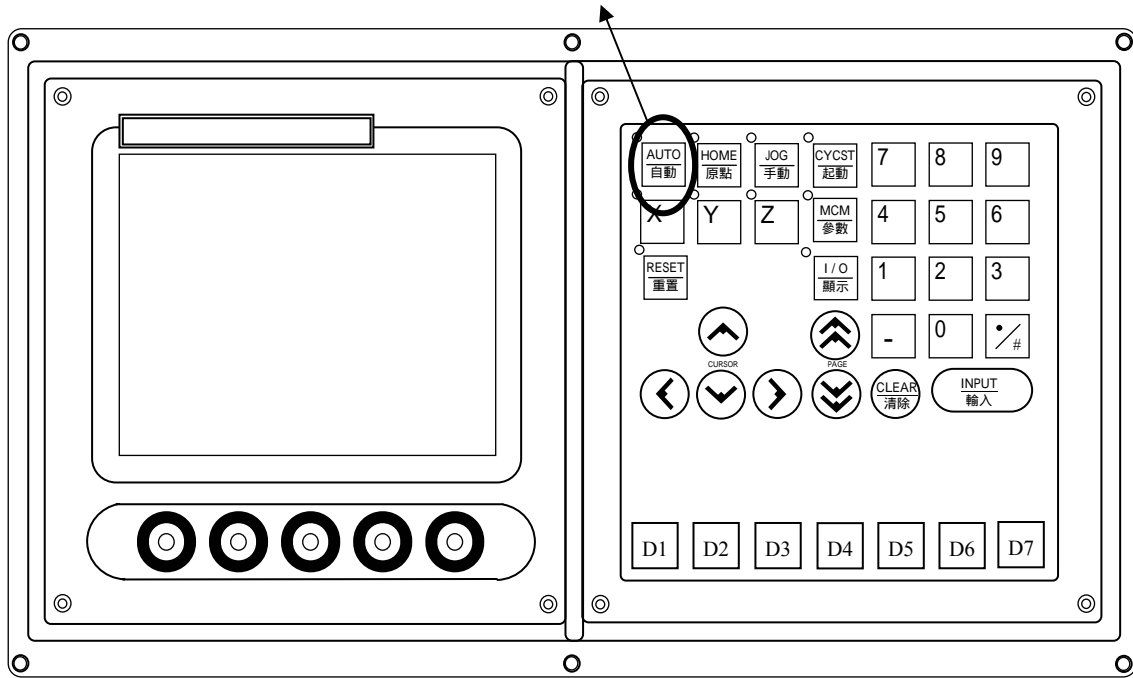

Caution !!! When the power is reopened, plz execute 3 Axes to home

## 二、 AUTO mode : (main page)

AUTO		FILE 000			Reaching-End				
N	X	R	$\alpha$	Vice	BL	C $\alpha$			
01	175.00		90.00						
02	100.00			1					
03	50.00								
L-Pos.				D-Pos.					
R-Pos.				G $\alpha$					
SD-Pos.				T-Time					
C-Time									
Next		For		Edit		Set		Lock	

AUTO		FILE			Reaching-End				
<b>L</b>		576.000			T-Time				
<b>D</b>		100.880			0				
<b>R</b>		0.000			C-Time				
					0				
N	X	R	$\alpha$	Vice	BL	C $\alpha$			
01									
Next		For		Edit		Set		Lock	

The “Bigger Word Coordinate” switched by “D1” or “AUTO”

### (一) Function key :

#### 1. CYCST : Cycle start

(1) Press this key to run the program.

(2) When the program is running, the LED-light located left-up of the CYCST will be on. Then the number of piece bended will begin to be counted.

#### 2. Lock :

When pressing this key, the running program will stop at this step.

Press again to cancel.

#### 3. RESET :

CNC gives an order to controller that let it stay on the non-mode, and the frame jumps to the non-mode page.

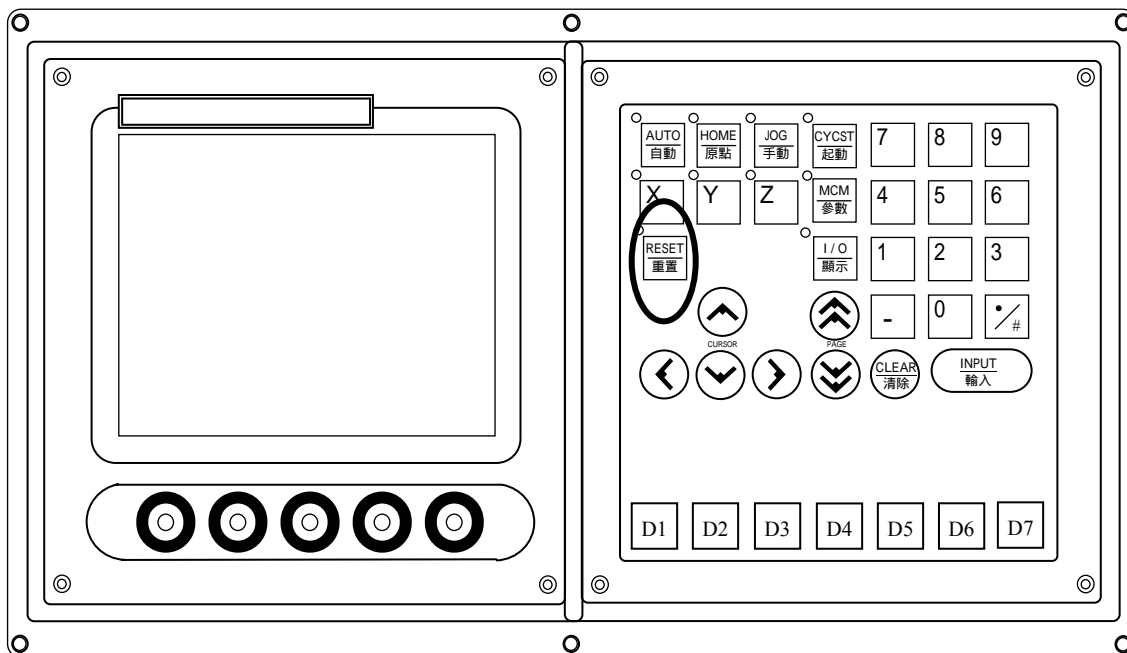

4. Edit :

When pressing this key on any mode, the controller will execute RESET first. Let the controller stay on non-mode status and then jump to the file-set page.

5. Set :

(1) When pressing this key on any mode, this key will highlight. It means that the controller is not running any program. And use CURSOR key to set the value of Total-Cor.(G ), SD-Pos., Total-number(T-Time) and Count number(C-Time).

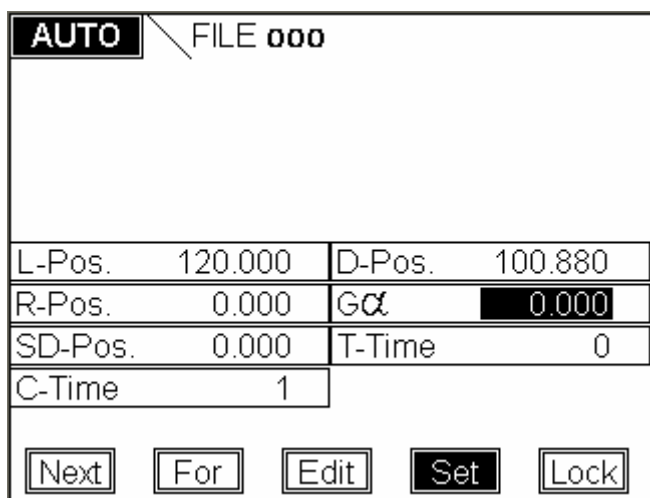

## 6. FORWARD : Execute last program

Do not press the NEXT key again when the white light is not canceled.

Because the program is not running over

## 7. NEXT : Execute next program

Do not press the FORWARD key again when the white light is not canceled.

Because the program is not running over

## (二) Additional description : When the setting key is highlight

1. Total correction ( G $\alpha$  ) :

Programs in the file are all corrected

When trying to bending 90 degree, the angle is

not enough : Set value positive

too deep : Set negative value

## EX 1 :

1. The Y-axis ( D-axis ) movement of one unit is set as 0.01 ( P- D = 0.01 ).

Set in the mode of Edit - FOLD - UN-SET.

2. G = 5.000 ( total correction )

3. The unit of the total correction is

$$P- D \times G \div 1000 = 0.010 \times 5000 \div 1000 = \underline{\underline{0.05 \text{ mm}}}$$

## EX 2 :

1. The Y-axis ( D-axis ) movement of one unit is set as 0.04 ( P- D = 0.04 ).

Set in the mode of Edit - FOLD - UN-SET.

2. G = 5.000 ( total correction )

3. The unit of the total correction is

$$P- D \times G \div 1000 = 0.040 \times 5000 \div 1000 = \underline{\underline{0.2 \text{ mm}}}$$

## 2. SD-position :

Input the location of angle-axis directly. Then press 【CYCST】 key to execute it. When the position is arrived, the number of D-axis will be canceled automatically. At this time we can press 【CYCST】 key to run the program directly.

## 3. T-Time :

Set total number of pieces

4. C-Time :

When it has run all the programs, the number will be added by 1 (Number of piece)

(≡) Display :

1. Press RESET to the frame of non-mode.

2. Status display

(1) When the number of work pieces is up to the setting : The MARK

【Reaching-End】 will highlight if the setting value is not equal to 0 OR current number is > or = the setting number.

(2) K-OUT 0

(3) UP-H 0

(4) UN-H 0

(5) UN-V 0

(6) TH 0

When status is shown, it can not be operated by controller.

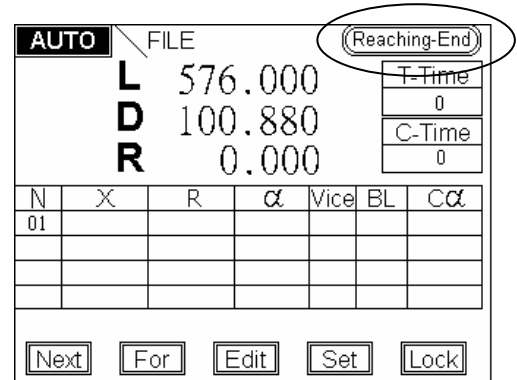

3. L-axis : ( X-coordinate )

Show the position of L-axis right now.

4. D-axis : ( Y-coordinate )

Show the position of D-axis right now

5. R-axis : ( Z-coordinate )

Show the position of R-axis right now

### 三、 File setting page :

M	Stainless	SET-FILE : 0 → 500				
TH	2.000	FILE : 0				
UP	116.000					
UN	70.000	K-OUT 2	20.000			
V	12.000	K-OUT 1	10.000			
N	X	R	$\alpha$	Vice	BL	C $\alpha$
01	175.000		90.00			
02	100.000		90.00	1		
03	50.00		90.00	1		

○

Edit	Type	Fold	PRO-S	Ret
------	------	------	-------	-----

- (一) 【Show】 the maximum number of file can be set.
- (二) Press the number keys on the keyboard directly. Input the number of file ( Number will show up the EDIT key.) When input the number of file and then press INPUT key, “data loading please wait...” will show below. When it disappears , we can choose other function key.
- (三) After the number of file is set, please go to the page of BENDING-SELECTION and TYPE-SET to enter correct data. Then we go to the EDIT page input bending program.
- (四) Edit :  
Go to the program-edit-set page
- (五) Type :  
Go to type-set page. See the page of type demonstration
- (六) Bending :  
Go to bending page. See the page of type demonstration.
- (七) Program selection key :  
Go to the main page of program number selection.
- (八) In this page ,Thickness ( TH ) , material ( M ) ,highness of upper-UNIT CHICE ( UP )( UN ) , inner width( V )and keep-out( K-OUT ) are shown their relative information in that file. If we want to change them, we can go to the page of TYPE or BENDING to do some correction.

The main page of program number selection

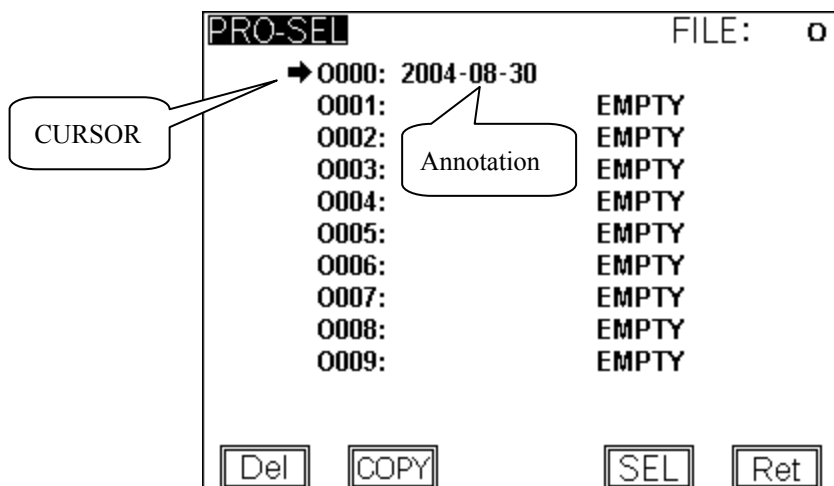

- (1). Press **【PAGE】** or **【CURSOR】** key to move the cursor.
- (2). **【Ret】** key : back to the **File setting page**.
- (3). **【COPY】** key : go to the **PRO-COPY page**.
- (4). Move to the set number then press the SELECT **【SEL】** key.

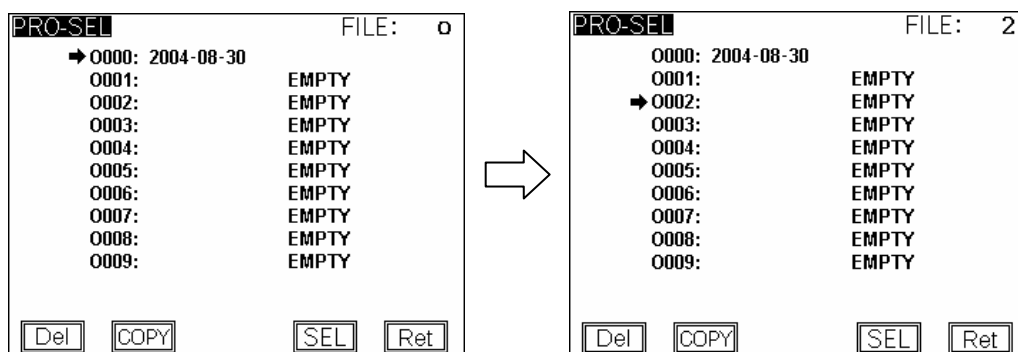

- (5). DELETE **【Del】** key: When you are trying to delete the program number the cursor pointing at, the confirming line will be shown as the picture below  
 Press **【Y】** : Delete the content of the program.  
 Press **【N】** : Back to the former page.

PRO-SEL		FILE:	<input type="radio"/>
➔ 0000:	2004-08-30		
0001:		EMPTY	
0002:		EMPTY	
0003:		EMPTY	
0004:		EMPTY	
0005:		EMPTY	
0006:		EMPTY	
0007:		EMPTY	
0008:		EMPTY	
0009:		EMPTY	
DELETE 0000 (y/n)?			
<input type="button" value="Y"/>		<input type="button" value="N"/>	

The program-copy page

PRO-COPY		FILE:	<input type="radio"/>
➔ 0000:	2004-08-30		
0001:		EMPTY	
0002:		EMPTY	
0003:		EMPTY	
0004:		EMPTY	
0005:		EMPTY	
0006:		EMPTY	
0007:		EMPTY	
0008:		EMPTY	
0009:		EMPTY	
SOURCE <input type="radio"/>		TARGET <input type="radio"/>	
<input type="button" value="SOURCE"/>		<input type="button" value="TARGET"/>	
<input type="button" value="COPY"/>		<input type="button" value="Ret"/>	

- (1). Move the cursor to the program number to be copied and press the **【SOURCE】** key.
- (2). Then move the cursor to the program number to be placed and press the **【TARGET】** key.
- (3). Press the **【COPY】** key. The operation of copying program will be executed.

## 四、 Edit mode

EDIT		FILE				
N	X	R	$\alpha$	Vice	BL	C $\alpha$
01	175.00		90.00			
02	100.00			1		
03	50.00					

Input area ←

Ins	Del	Vice	Bto	Ret
-----	-----	------	-----	-----

(一) Press the CURSOR key to move to the column to be input. Then input the value.

(1). When the cursor is located on the last line of program, by pressing the cursor-down key the controller will insert one blank program line automatically. If you are not going to use this blank program line, please press the DELETE key to delete this blank program.

(2). If you want to set the value as “BLANK”, you can press the CLEAR key first and then press the INPUT key. The setting column will be on the blank status.

(二) BTO key : (Back To One)

Move the cursor back to the first node.

(三) MCM key :

Go to the PARAMETER setting page.

(四) DELETE key : ( Del. )

Delete the setting value of one line.

(五) INSERT key : ( Ins. )

Insert one line of blank program below current cursor.

PS :

(1). When the MCM setting value is 0, the program has no recycle and no DX. It ranges from 0 to 10.

Ex : Function setting ( Vice )

Value 1: The program will execute first motion by the MCM-setting page.

Value 2: The program will execute second motion by the MCM-setting page.

ETC...

- (2). If there is some blank node, please delete it. Or it will effect on the operation of simulation and rebirth.

## 五、 MCM ( Vice ) setting page:

---

VICE \ VICE 10 \				
Vice	Cyc	Time	Ran	Count
1	0	0.0	0.000	0
2	0	0.0	0.000	0
3	0	0.0	0.000	0
4	0	0.0	0.000	0
5	0	0.0	0.000	0

PD Ret

### (一) Cycle : ( Cyc )

Square input-area number chosen

value 1 → Successful recycle. 【bending arc】

value 0 → Failed recycle. Only run the distance of DX

By using this function you must set counter value as not zero. Or this function will be useless.

### (二) Delay Time : ( Time ) Range from 0 to 9.9s

Cycle setting value 【1】: The pausing time is set as when executing cycle motion for bending arc, there is a pausing time between each time bending.

### (三) DX :

Set the distance of X-axis move out or cycle when bending.

### (四) Count :

If the cycle setting value is 1, the program motion will proceed orderly by 【Ran】 setting value.

Ex : If the 【Ran】 value is 3mm, 【count】 value is 10 , X-axis will proceed 3mm and repeat 10 times. And each time will proceed after I007 signal changes on to off.

**Attention :**

When the cycle setting value is 1 , we must notice that if the total distance of cycle will be over X initial coordinate. 【 between X difference and keep-out setting】 If it dose, system will adjust cycle value automatically.

**EX:**

Set value of cycle to 1,【Ran】to 3, 【count】 to 10, X initial coordinate to 20.000, keep-out area to 7.9, System will adjust it to 4 times automatically.

$$3 \times 10 = 30$$

$$20 - 7.9 = 12.1$$

$30 > 12.1$  , 【count】 value will turn to 4 automatically.

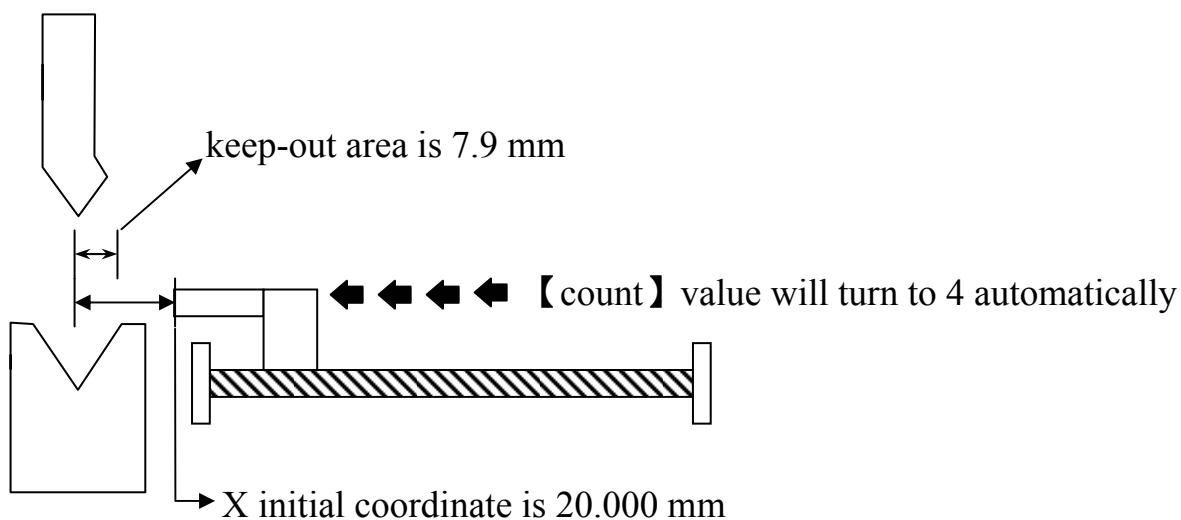

**六、 Type setting page:**

TYPE		FILE	
1.	TH 2.000	UP-H	116.000
2.	M 1 Stainless	UN-H	70.000
3.	BL 1670	UN-V	15.000
4.	UP 1		
5.	UN 1		
→ Pressure 15.36 Ton			
		Pre.	Ret

- (一) Thickness : ( TH )  
Input the thickness of bending piece.
- (二) Material : ( M )  
Setting : 0 = > Stainless steal.  
1 = > Iron.  
2 = > Aluminum.
- (三) Upper- CHICE : ( UP )  
Input the number of upper- CHICE
- (四) Unit-CHICE : ( UN )  
Input the number of unit- CHICE
- (五) Calculation : ( Pressure )  
When finishing inputting data of bending-selection and type, the bending pressure needed will shown up by pressing this key
- (六) Width : ( BL )  
Calculate all the conditions about bending pressure.

## 七、 Bending-selection for fold setting page : ( FOLD )

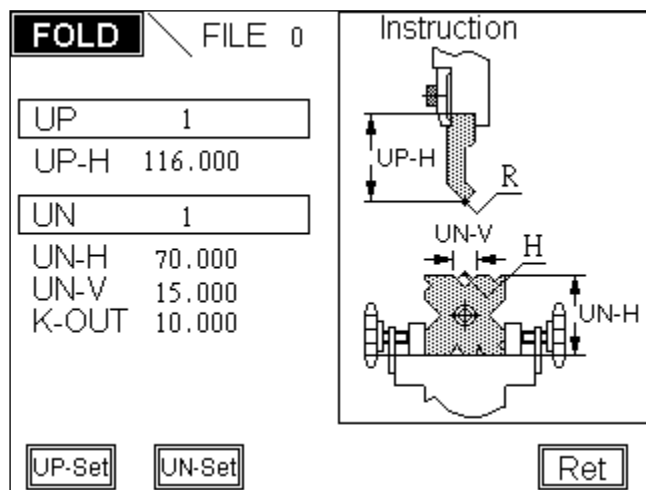

- (一) Upper-CHICE number : ( UP )  
Input the serial number of upper- CHICE
- (二) UNIT- CHICE number : ( UN )  
Input the serial number of unit- CHICE



PS2 :

1 : SMALL K-OUT setting.

2 : BIG K-OUT setting.

It must be careful to setting the K-OUT value.

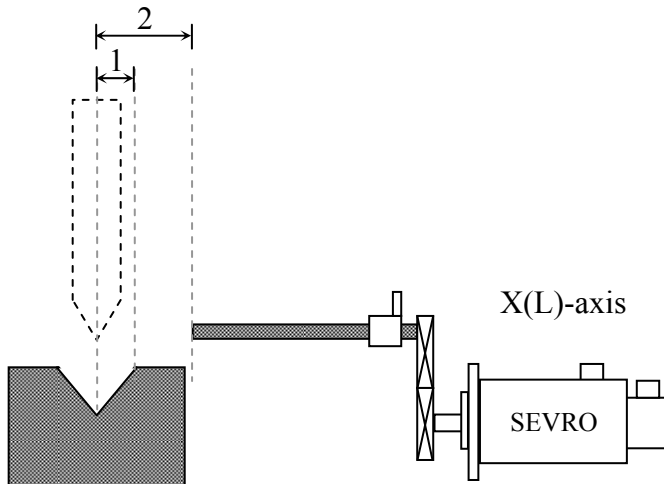

## 八、 JOG mode

(一) The page will move to JOG mode by pressing  key. (this key will fail when the program is running)

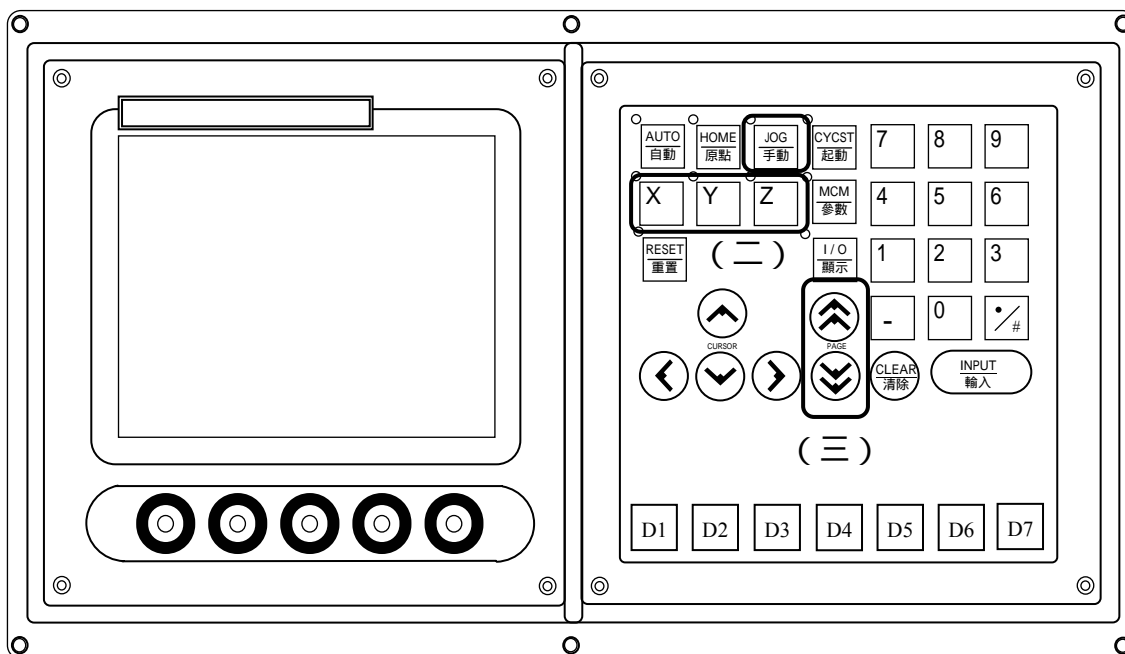

(二) Choose axis value of JOG by MPG or choose it on the keyboard.  
When the MPG is off, then the function on the keyboard is on.  
L-axis(X)、 D-axis(Y)

Parameter 22 = 0 : The function is on by MPG hand wheel.

Parameter 22 = 1 : JOG operation on the keyboard.

**Setting by engineer**

( 三 ) Turn the “MPG” or press “PAGE” key → Manual control

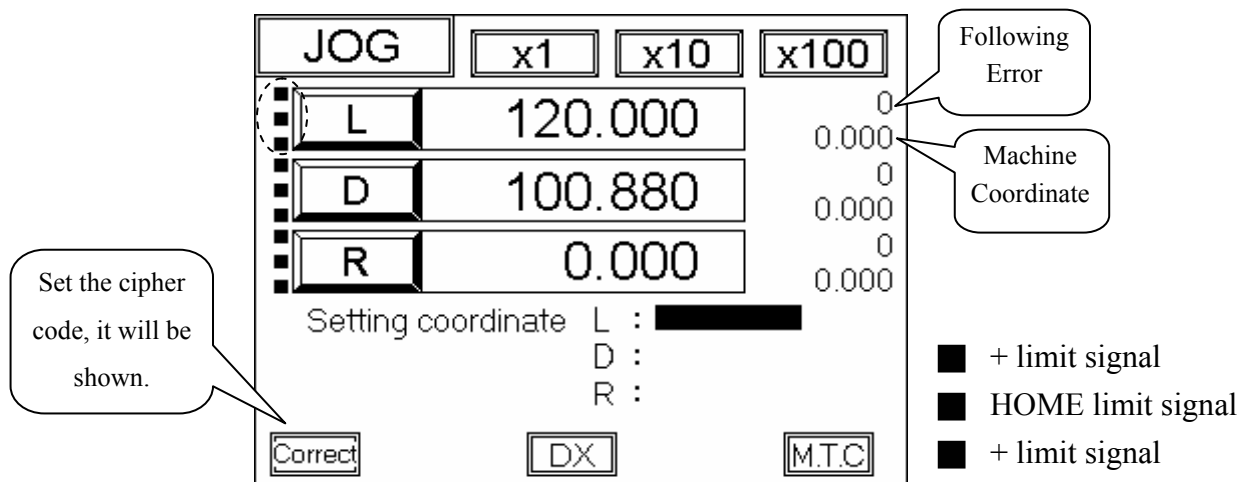

( 四 ) After inputting assign point of each axis, by pressing the “M.T.C” key, the axis will move to the assign coordinate.

When executing this operation, some error maybe occur :

Err 51 : The X -axis ( L-axis ) positive way assign value is bigger than the setting value.

Err 52 : The X -axis( L-axis )negative way assign value is smaller than the “Keep-Out” area value.

Err 53 : The Y -axis ( D-axis ) positive way assign value is bigger than the setting value.

Err 54 : The Y -axis( D-axis )negative way assign value is smaller than the setting value.

Err 55 : The Z -axis ( R-axis ) positive way assign value is bigger than the setting value.

Err 56 : The Z -axis( R-axis )negative way assign value is smaller than the setting value.

(五) DX : ( add pressure limit )

When this function is on, it will highlight. When the DX signal ( I007 = 1 ) is coming in, the X-axis will do the operation of DX. The distance is based on the VICE of the 10th group of EDIT MODE.

(六) Correct : 【Just only L-axis ( X )】

1. move the L-axis and measuring.

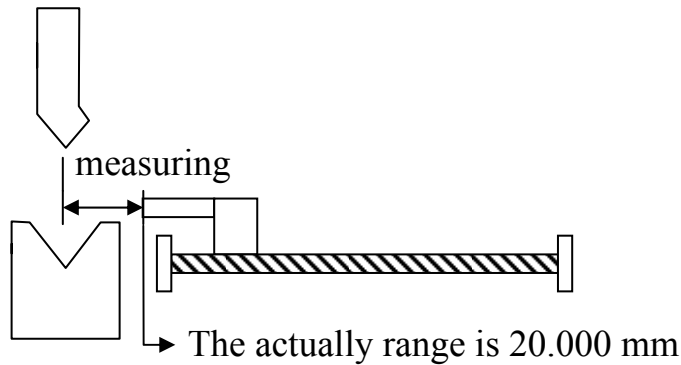

2. Enter the L-axis of measuring value : **20.000**
3. Press the Enter key twice to correct the error.

The coordinate correction page

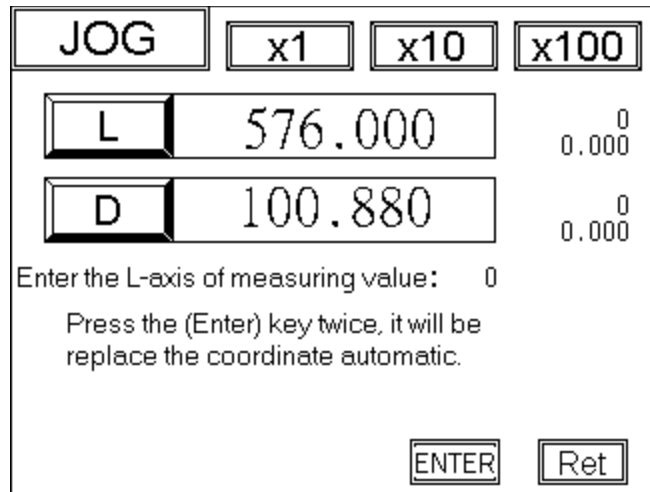

## 九、 HOME mode

(一) It will move to the HOME-mode page by pressing  key ( This key will fail when the program is running.)

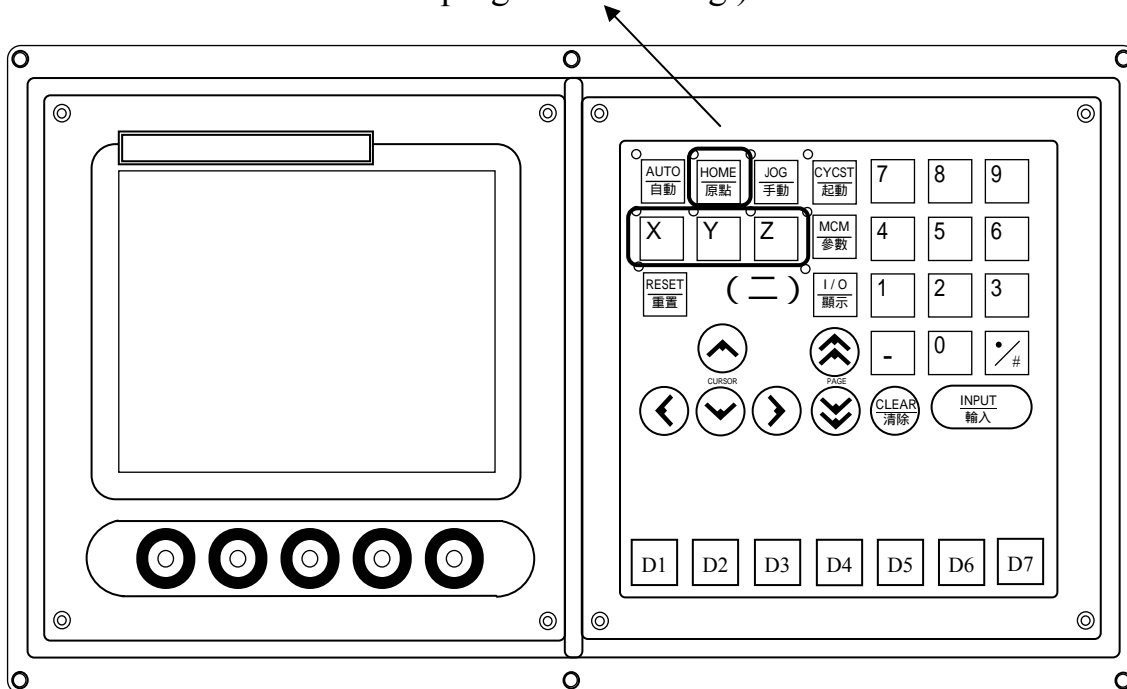

(二) Choose axis to home operation on the keyboard.

L-axis(X)、D-axis(Y)、R-axis(Z)

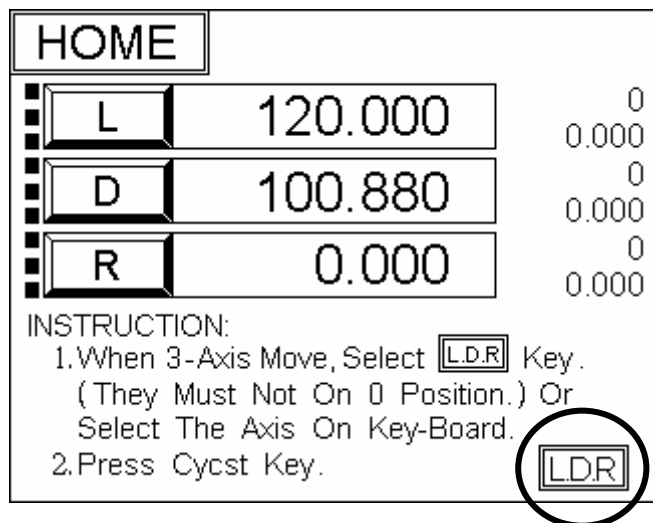

(三) Press CYCST key. Motor begins to execute the motion to HOME.

(四) After the motion done, press AUTO key to the main page.

## 十、 Error and Absolve ( total Error page )

---

### **EMG-STOP**

POWER RESTARD

### **OVER - TRVL**

AXIS IS OUT OF THE LIMIT

Please Turn To Manual Mode,And  
Move The Axis Into The Limit.

### **KEEP-OUT**

L-AXIS IS INTO THE "K-OUT" RANGE

STEP:

1. PUSH L-AXIS OUT OF THE "K-OUT"  
OR RESET THE "K-OUT" RANGE.
2. PUSH "RESET" KEY.
3. EXECUTE "HOME" OPERATION

## **SERVO ERROR**

### **POWER RESTART**

## **MESSAGE**

- 1.Last time before the power off, there was the signal of servo error .
- 2.Correspondent axis must be executed to return the machine coordinate, then you can press cycst.

## 十一、 Bending Machine I/O List

INPUT		INFORMATION	OUT	INFORMATION
0	NC	L-axis Limit (hardware + )	0	Oil - Stop
1	NC	L-axis Limit (hardware - )	1	L-AXIS SERVO-ON
2	NC	D-axis Limit (hardware + )	2	D-AXIS SERVO-ON
3	NC	D-axis Limit (hardware - )	3	R-AXIS SERVO-ON
4	NC	Emergent Stop (EM-STOP)	4	NC ALARM
5			5	EM-STOP
6	NO	Re-CYCST ( Oil Upper Limit )	6	
7	NO	DX signal ( add pressure limit )	7	
8	NC	L-axis Home Limit	8	
9	NC	D-axis Home Limit	9	
10	NC	R-axis Home Limit	10	
11	NO	MPG -X-axis	11	
12	NO	MPG -Y-axis	12	
13	NO	MPG -Z-axis	13	
14	NO	MPG × 1	14	
15	NO	MPG × 10	15	
16	NO	MPG × 100		
17	NC	R-axis Limit (hardware + )		
18	NC	R-axis Limit (hardware - )		
19				
20	NO	“CYCST” key unused		
21				
22				
23				

NO : Normally-Open

NC : Normally-Close

**OT limit and HOME limit can be found in the parameter page 2. They are set as Normally-Open or Normally-Close. And the default is Normally-Close.**

Press this  key, the I/O signal will be shown :

I00 L axis OT +	I14 MPG - x1
I01 L axis OT -	I15 MPG - x10
I02 D axis OT +	I16 MPG - x100
I03 D axis OT -	I17 R axis OT +
I04 EM-STOP	I18 R axis OT -
I05	I19
I06 RE-START	I20 Cycst signal fail
I07 DX-SIGNAL	I21
I08 L axis HOME Limit	O00 Oil system stop
I09 D axis HOME Limit	O01 L axis Servo ON
I10 R axis HOME Limit	O02 D axis Servo ON
I11 MPG - X	O03 R axis Servo ON
I12 MPG - Y	O04 NC ALARM
I13 MPG - Z	O05 EM-STOP

## 十二、 Machine Connection Diagram

### Input Signal

(Input Board)Connect signal line to input board of HUST, and then connect to input connector on the H3BN through DB25LF of the input board. Using HUST input board has an advantage that it will protect the controller lines of H3BN series. This connecting way is only suit for the input connector of NPN type

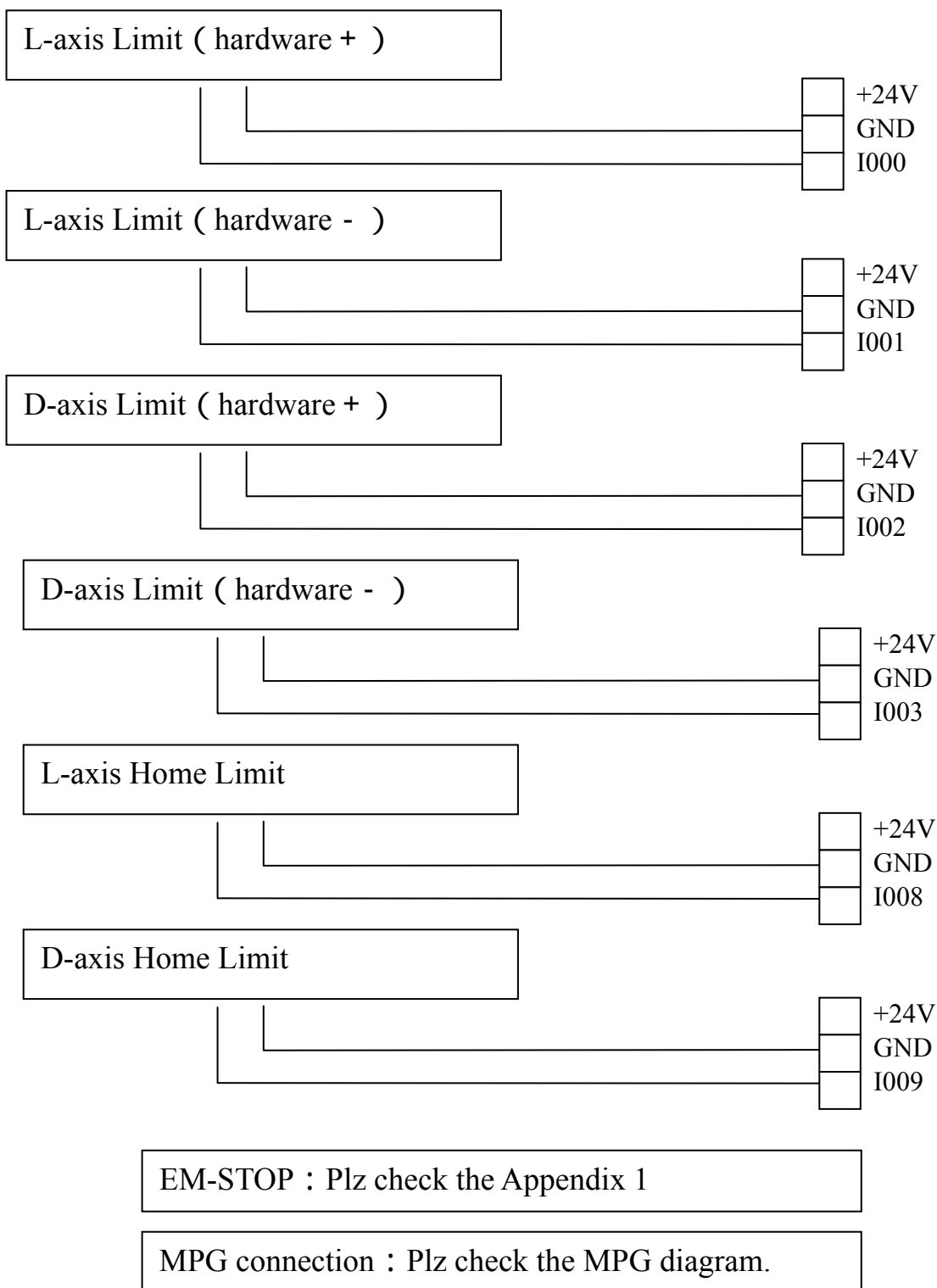

**Output Signal Type**

- (a) If we use output relay-board, each joint can sustain up to 250V(alternate) and 1A.
- (b) If we don't use output relay-board, each joint can only sustain up to 24V and 100mA.

**Oil System Interruption**

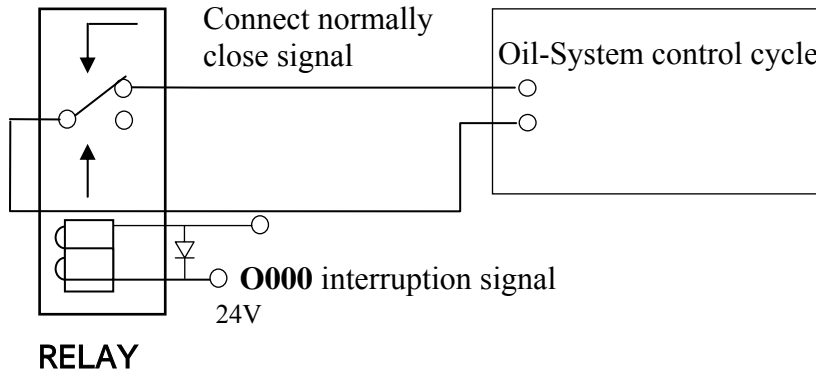

**L-axis, D-axis, R-axis SERVO-ON**

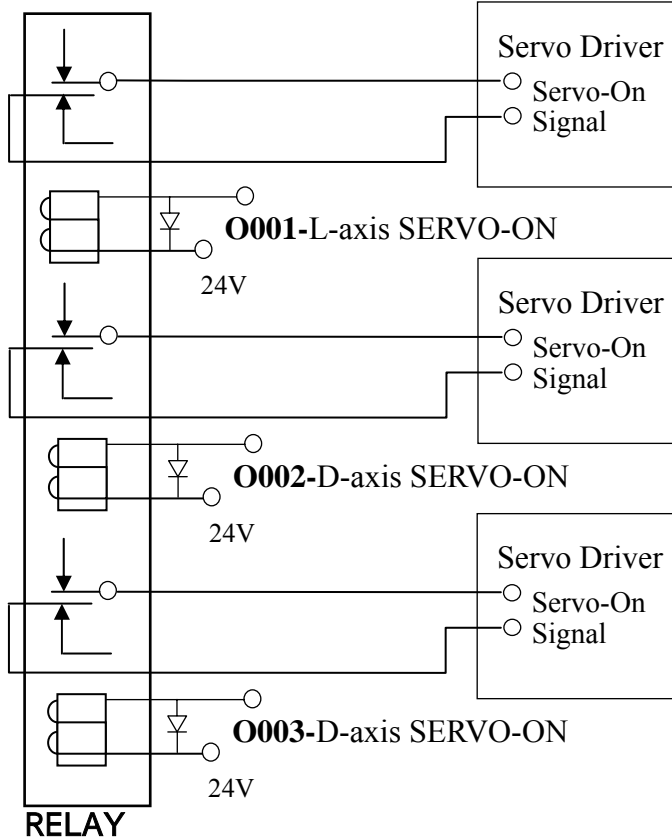

**Machine Illustration**

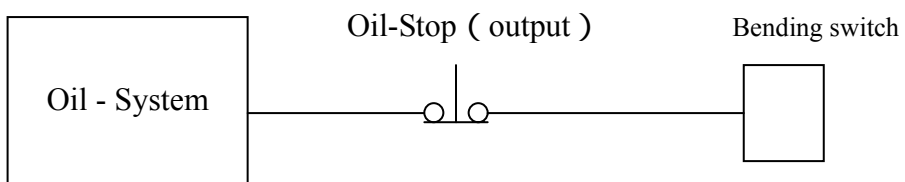
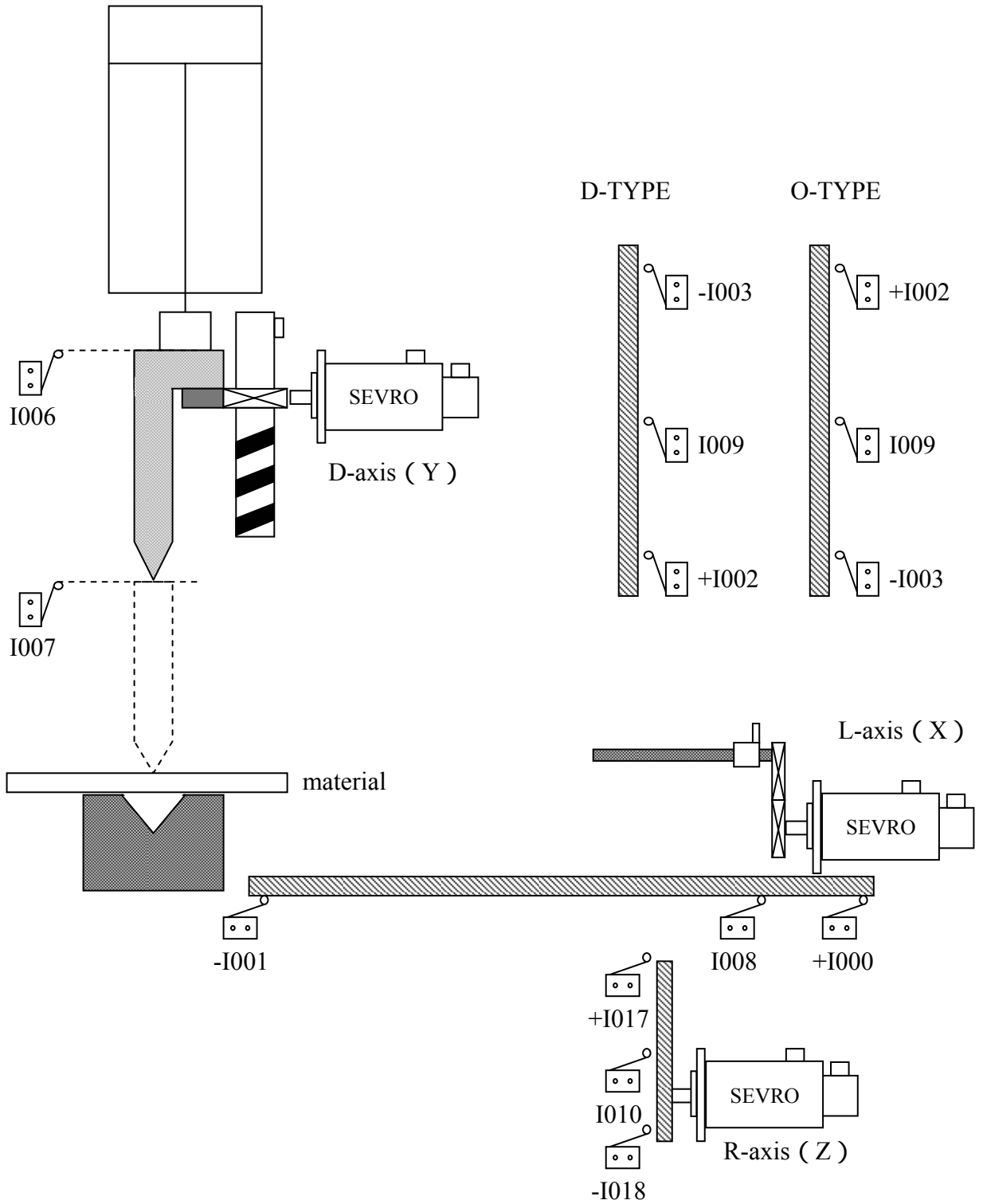

## Appendix 1 : Emergent Stop Connection Diagram

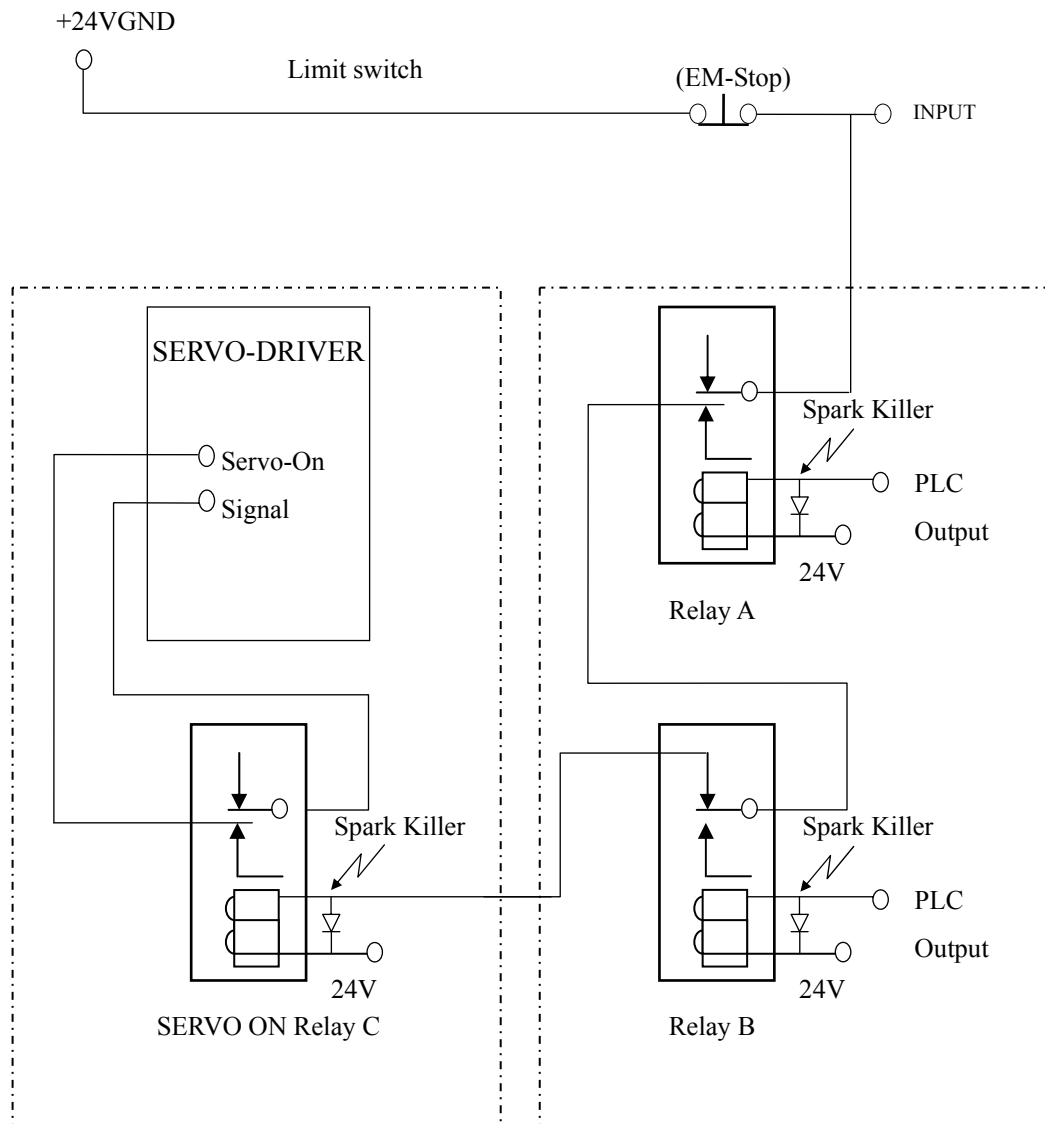

### Emergent Stop Connection

PS :

1. Relay A、 B are protective lines for starting. They prevent the controller starting failure. Output will destroy machinery construction.
2. Relay C is servo-on relay.
3. Relay A、 B are two outputs in PLC.
4. Relay C commonly is multi-joint. Each driver needs an unique joint. And some drivers can't.
5. The PLC edition of servo-on is mentioned in appendix-3.

## Appendix 2 : Servo Driver Servo-On Connection Diagram

Wrong way :

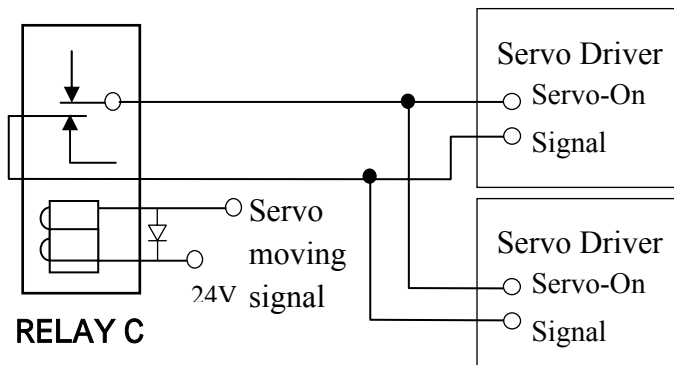

Right way:

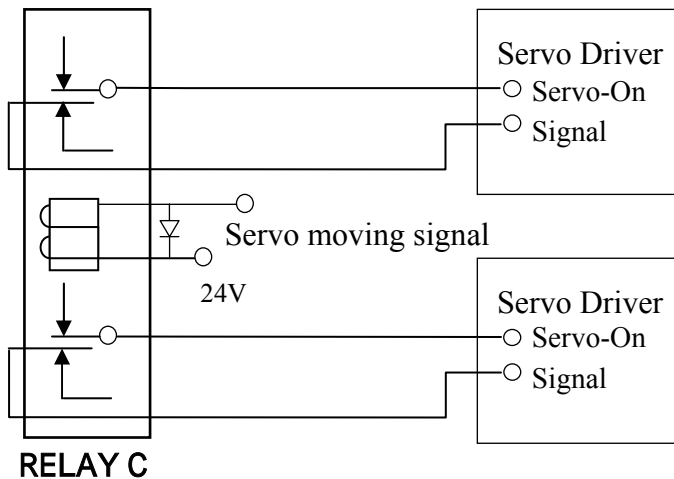

Right and Wrong way of driver connection

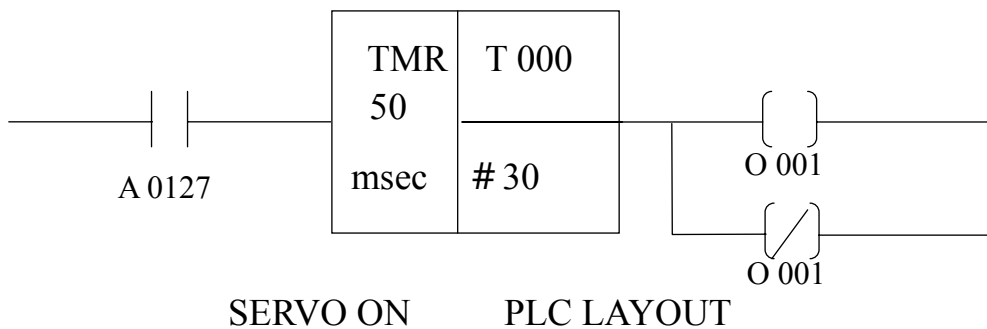

## Appendix 3 : H4B Numeral Control Box Only For Bending Machine (Back)

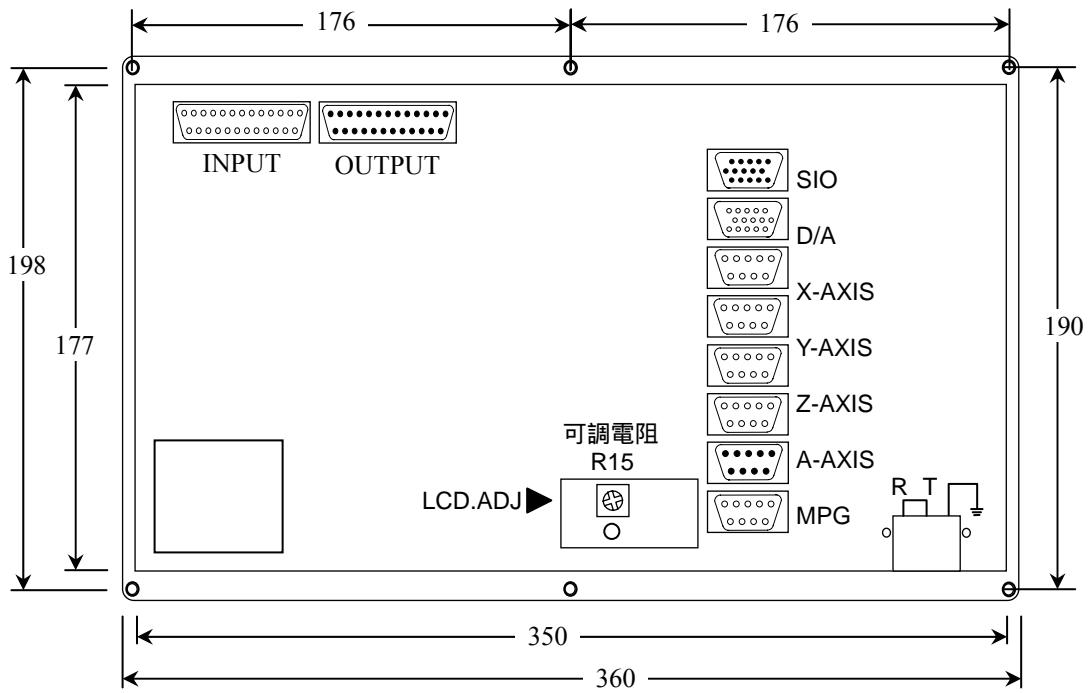

### H4B The Size of Box (Upper)

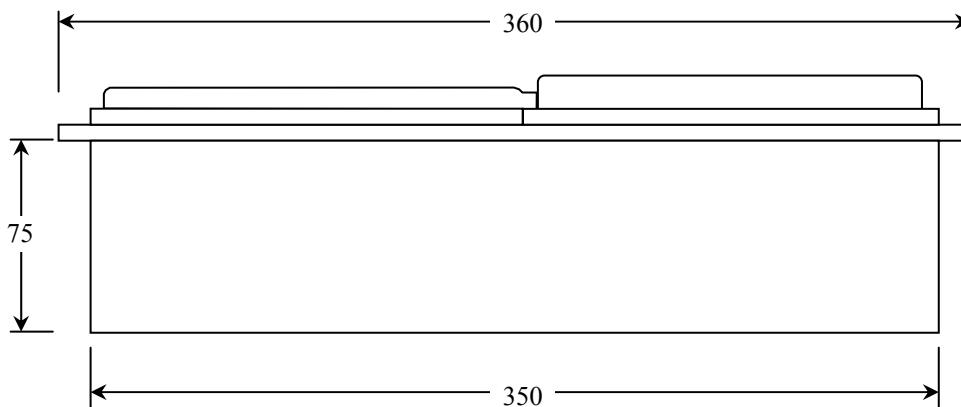

## Appendix 4 : Bending Angle Conception

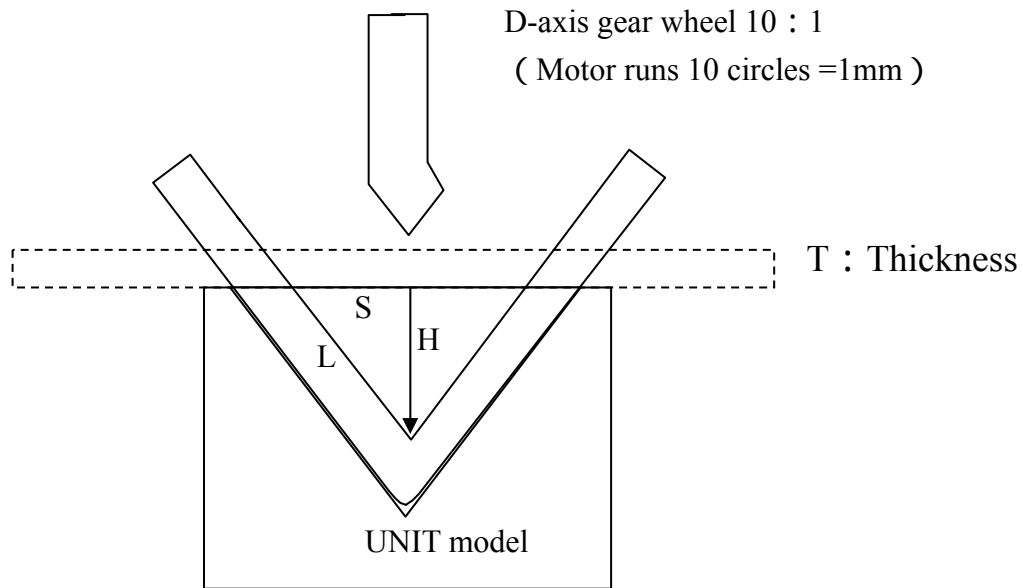

$$\sin \theta = S/L ; \cos \theta = H/L ; \tan \theta = \sin \theta / \cos \theta = S/H ; H = S / \tan \theta$$

$$\sin \theta = S/L ; \cos \theta = H/L ; \tan \theta = \sin \theta / \cos \theta = S/H ; H = S / \tan \theta$$

Ex1 :

UNIT-CHICE model is 30mm width ( S = 15mm ) ; angle 90 degree ; the piece 2mm thickness (actual calculation uses  $\mu$  as unit)

Calculation :

- 1、  $90 \div 2 = 45$
- 2、  $\sin 45 = 0.707 ; \cos 45 = 0.707 ; \tan 45 = 1$
- 3、  $H = 15000 ( \mu ) \div 1 = 15000 ( \mu )$
- 4、  $15000 ( \mu ) - 2000 ( \mu ) = 13000 ( \mu )$
- 5、 13 mm Pressing Down Depth

EX2 :

UNIT-CHICE model is 30mm width ( S = 15mm Actual calculation uses  $\mu$  as unit ) ; angle 150 degree ; what is the pressing down depth H?

Calculation :

- 1、  $150 \div 2 = 75$
- 2、  $\sin 75 = 0.9659 ; \cos 75 = 0.2588 ; \tan 75 = 0.9659 \div 0.2588 = 3.7322$
- 3、  $H = 15000 ( \mu ) \div 3.7322 = 4019.077$
- 4、  $4019.077 ( \mu ) - 2000 ( \mu ) = 2019.077 ( \mu )$
- 5、 2.019 mm Pressing Down Depth

# Appendix 5 : H4B Control Structure of Bending Machine

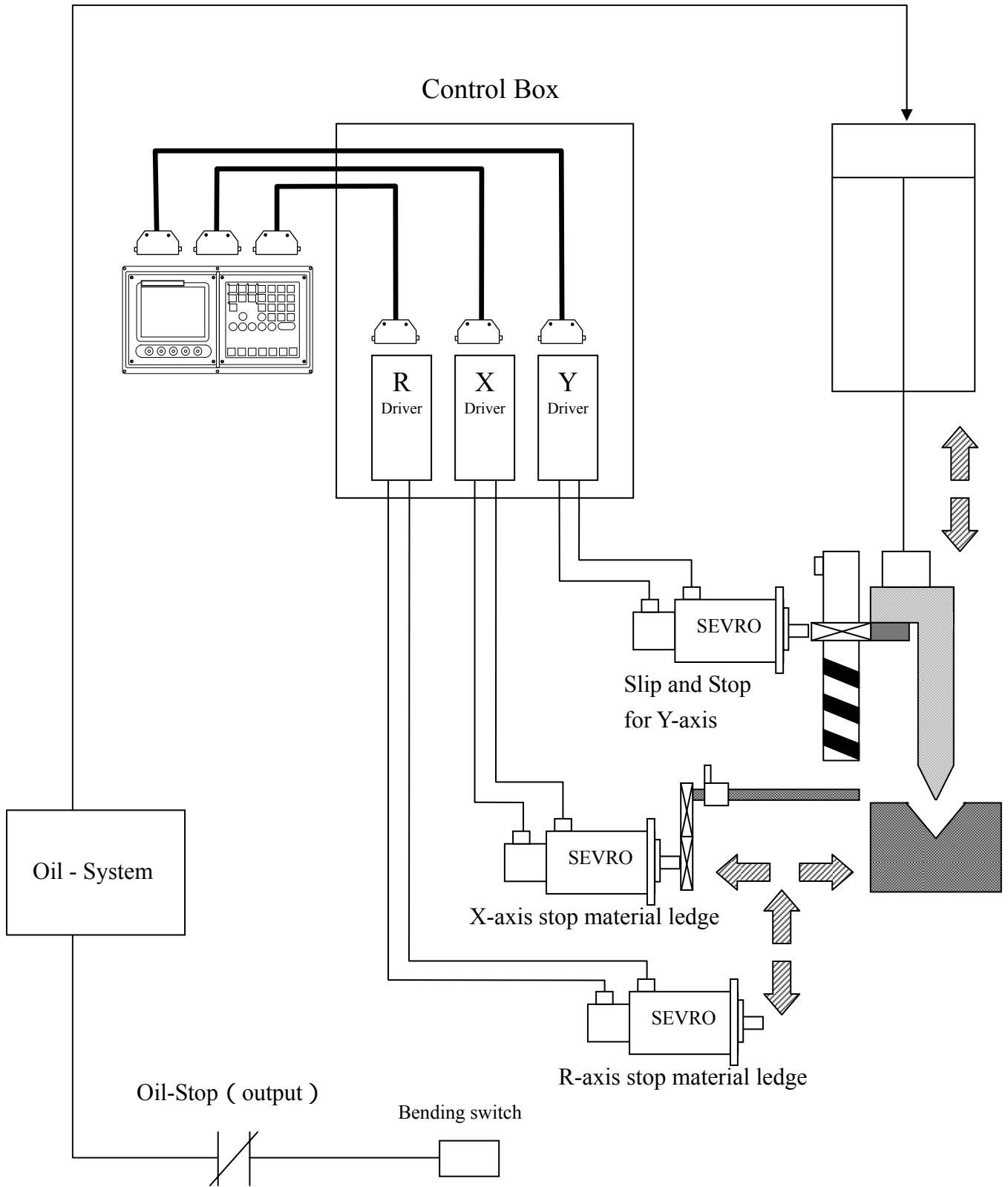

## Appendix 6 : MCM (Parameter)

Input the password

1 : \* \* \* \*

2 : \* \* \* \*

Parameter cipher  
0, if you first into the parameter page, it will ask you input the cipher code.

SYSTEM	2005	316
PLC	2005	322
PROGRAM	2005	301

Edition date

The function key shown is set by parameter, don't operation except engineer !

B_MCM	B_VAR	CLR_P	LD VAR	LD MCM
-------	-------	-------	--------	--------

Then press "MCM" key twice quickly to go to the page below

Parameter	X-AXIS	Y-AXIS	
Resolution-DEN			
Resolution-NUM			
Encoder Factor			
Traverse Speed			
Rotate Direction			
Home Direction			
Home Speed 1			
Home Speed 2			
Software OT+ 1			
Software OT- 1			
Backlash Comp			

Parameter	X-AXIS	Y-AXIS	
MPG - NUM			
MPG - DEN			
Software OT+ 2			
Software OT- 2			
JOG Feed-Rate			
Setting the range of Grid			
Home Limit			
OT Limit			

( 0:NC 1:NO )



PAGE 3

Y-Opening default setting	
D-axis HOME limit setting	
G00 Linear accel/decel	
MPG direction	
MPG Accel/Decel time	
0=Metric mode 1=Inch mode	
Language 0=Chinese 1:English	



PAGE 4

Basic parameter cipher code 1	0
Basic parameter cipher code 2	0
Parameter list 0=NO , 1=YES	0
Lock the function key on the mcm page	0
The basic point of Y-axis HOME direction	-0.050
The calculation of Y-opening default	0
The mode after Power-On	0

Y: 0.000

Y SET 0 CLR\_ALL



The function key shown is set by parameter, don't operation except engineer !





Note that the length of the Home limit switch should be longer than the distance for the deceleration of Speed 1. Otherwise, serious error may result. The equation to calculate the length of the Home limit switch is

$$\text{Length of Home Limit Switch (mm)} \geq \frac{\text{FDCOM} * \text{ACC}}{60000}$$

FDCOM = Speed 1, in mm/min. (MCM #136~ #139)

ACC = Time for acceleration/deceleration, in ms. (MCM #167)

60000 = 60 seconds = 60 \* 1000 milliseconds

When the C-bit C063=1 in PLC program, it commands the controller to do homing operation. Do homing operation for X-axis if R232=1, do Y-axis if R232=2, do Z-axis if R232=4, do A-axis if R232=8 and do four axes simultaneously if R232=15.

Ex: FDCOM = 3000.00 mm/min, and ACC = 100 ms

Length of Home Limit Switch = 3000 \* 100 / 60000 = 5 mm

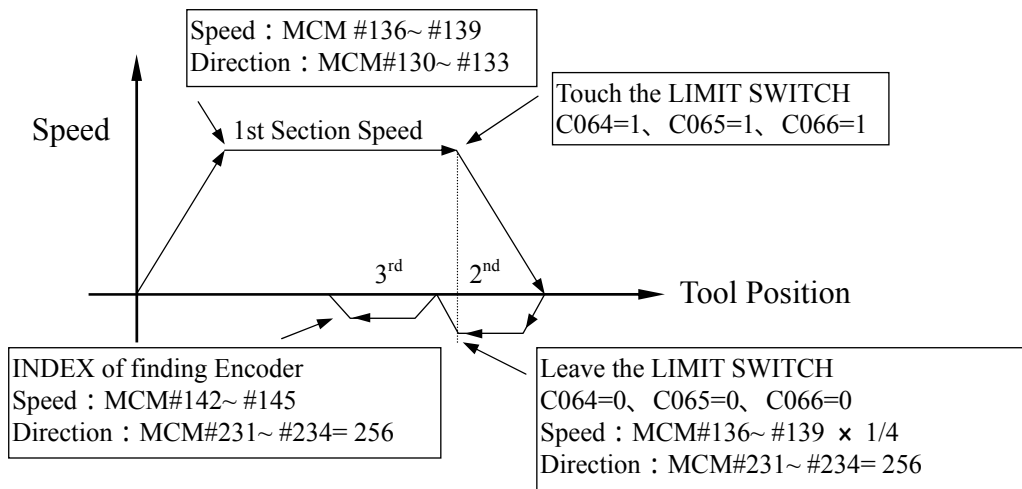
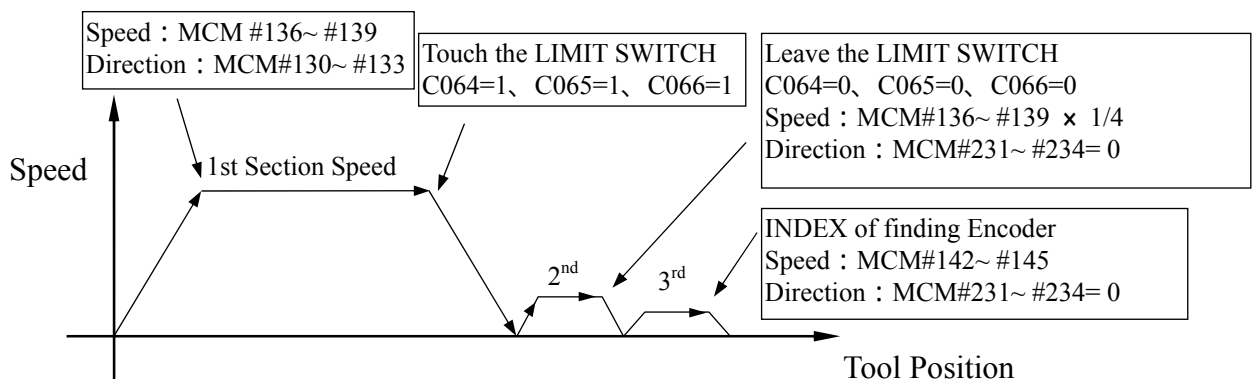

Fig A Homing Speed and Direction of finding ( GRID )









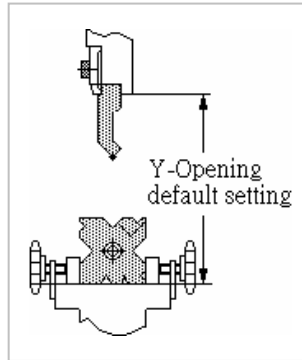

22. D-axis HOME Limit setting                      Format :                      .                      (Default = 0.000)

Show the coordinate when finish the HOME operation

23. R-axis HOME Limit setting                      Format :                      .                      (Default = 0.000)

Measure the distance when finish the HOME operation

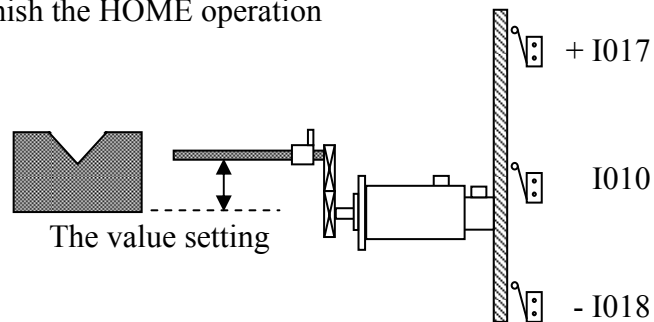

24. G00 Linear accel / decel                      Format :                      (Default = 100)

Unit: millisecond

Setting Range: 4 ~ 512 millisecond.

25. MPG direction                      Format :                      (Default = 0)

Adjust the MPG direction (Positive or Negative to the Axis)

According to the bit, bit 0 represents X-axis, bit 1= Y-axis, and bit 2=Z-axis.

EX1: When tending to change the MPG direction of Y-axis, its setting is 2

EX2: When tending to change the MPG direction of X-axis and Y-axis, it's setting is 3.

26. MPG Accel / Decel time                      Format :                      (Default = 64)

Unit: milliseconds

Setting Range: 4~512 ms.

The motor acceleration / deceleration time is equal to MCM #236 when MPG hand-wheel is used in JOG mode.





## PARAMETER LIST :

MCM serial	Set Axis	Default Value	Set Unit	Function Setting Information	For Customer
51		0		Master-Slave function setting. 0=None, 1=X-axis, 2=Y-axis, 3=Z-axis, 256=Round corner non-stop mode	
58	X	0	mm	Backlash compensation. 0~255 pulse	
59	Y	0	mm	Backlash compensation. 0~255 pulse	
60	Z	0	mm	Backlash compensation. 0~255 pulse	
61	X	1000	mm/min	X-axis JOG Feed-Rate & Power-On G01 Speed	
62	Y	1000	mm/min	Y-axis JOG Feed-Rate & Power-On G01 Speed	
63	Z	1000	mm/min	Z-axis JOG Feed-Rate & Power-On G01 Speed	
64	X	100	pulse	Denominator, resolution calc.(Encoder Pulse)	
65	X	100	μm	Numerator, resolution calc.(Encoder Pulse)	
66	Y	100	pulse	Denominator, resolution calc.(Encoder Pulse)	
67	Y	100	μm	Numerator, resolution calc.(Encoder Pulse)	
68	Z	100	pulse	Denominator, resolution calc.(Encoder Pulse)	
69	Z	100	μm	Numerator, resolution calc.(Encoder Pulse)	
70	X	0		X-axis HOME direction. 0=Positive,1=Negative	
71	Y	0		Y-axis HOME direction. 0=Positive,1=Negative	
72	Z	0		Z-axis HOME direction. 0=Positive,1=Negative	
73	X	2500	mm/min	X-axis HOME speed	
74	Y	2500	mm/min	Y-axis HOME speed	
75	Z	2500	mm/min	Z-axis HOME speed	
76	X	40	mm/min	X-axis HOME grid speed during HOME execution	
77	Y	40	mm/min	Y-axis HOME grid speed during HOME execution	
78	Z	40	mm/min	Z-axis HOME grid speed during HOME execution	
79	X	5000	mm/min	X-axis Traverse speed limit	Calculation
80	Y	5000	mm/min	Y-axis Traverse speed limit	Calculation
81	Z	5000	mm/min	Z-axis Traverse speed limit	Calculation
82	X	0		Direction of motor rotation, 0=Positive,1=Negative	
83	Y	0		Direction of motor rotation, 0=Positive,1=Negative	
84	Z	0		Direction of motor rotation, 0=Positive,1=Negative	
85	X	4		X-axis Encoder pulse multiplication factor. 1,2,4	
86	Y	4		Y-axis Encoder pulse multiplication factor. 1,2,4	
87	Z	4		Z-axis Encoder pulse multiplication factor. 1,2,4	
88		100	msec	G00 accel./decel. time. Linear (4~512)	
89		100	msec	G01 accel./decel. time. Linear (4~3072)	
90		9600		RS232C Baud rate 9600~38400/EVEN/2 BIT	
91		0		Current counter (M02,M30,M99)	
92		0		Counter limit (Max 9,999,999)	

MCM serial	Set Axis	Default Value	Set Unit	Function Setting Information	For Customer
93	X	9999999	mm	X-axis Software OT limit of positive direction	
94	Y	9999999	mm	Y-axis Software OT limit of positive direction	
95	Z	9999999	mm	Z-axis Software OT limit of positive direction	
96	X	-9999999	mm	X-axis Software OT limit of negative direction	
97	Y	-9999999	mm	Y-axis Software OT limit of negative direction	
98	Z	-9999999	mm	Z-axis Software OT limit of negative direction	
99	X	0	mm	HOME shift data	
100	Y	0	mm	HOME shift data	
101	Z	0	mm	HOME shift data	
104	X	0		X-axis Cycle clearing M02,M30,M99	
105	Y	0		Y-axis Cycle clearing M02,M30,M99	
106	Z	0		Z-axis Cycle clearing M02,M30,M99	
107	X	1		X-axis value, 0=Incremental, 1=Absolute	
108	Y	1		Y-axis value, 0=Incremental, 1=Absolute	
109	Z	1		Z-axis value, 0=Incremental, 1=Absolute	
110	X	0		X-axis setting. 0=Rotating, 1=Linear	
111	Y	0		Y-axis setting. 0=Rotating, 1=Linear	
112	Z	0		Z-axis setting. 0=Rotating, 1=Linear	
113		0		Reserve for system, 0 recommend	
120		1		PLC value such as R000~R099 be saved or not (When power off). 256/1=Yes,0=No	
121	X	0	mm	X-axis In-position distance	
122	Y	0	mm	Y-axis In-position distance	
123	Z	0	mm	Z-axis In-position distance	
124		0		Accel./Decel. mode. 0=Linear , 1="S" Curve	
127		3000	rpm	Spindle rpm at 10V	
132		100		Denominator of feed-rate when in MPG test mode	
133		100		Numerator of feed-rate when in MPG test mode	
135		100	msec	Spindle acceleration time.	
136	X	0		X-axis HOME grid direction during executing	
137	Y	0		Y-axis HOME grid direction during executing	
138	Z	0		Z-axis HOME grid direction during executing	
140		64	ms	MPG Accel./ Decel. Time ( 4~512 )	
141	X	100	pulse	X-axis Denominator resolution calc of MPG	
142	X	100	μ m	X-axis Numerator resolution calc of MPG	
143	Y	100	pulse	Y-axis Denominator resolution calc of MPG	
144	Y	100	μ m	Y-axis Numerator resolution calc of MPG	
145	Z	100	pulse	Z-axis Denominator resolution calc of MPG	
146	Z	100	μ m	Z-axis Numerator resolution calc of MPG	
147		0		0=Metric mode , 1=Inch mode	
148		1		Error in circular cutting.	

## Appendix 7 : Sanyo Servo Machinery Connection

### PY-PZ 【 Voltage Command 】 Connection Diagram

PY & PZ Driver  $\longrightarrow$  Controller

Sanyo PZ Sanyo PY			HUST CNC		Cable ( 3M 以下 )
3M 50 PIN F(D-connector)			9 PIN M(D-connector)		PIN Number
Blue	3		1	Blue	A
Green	4		2	Green	A -
Brown	5		3	Brown	B
Purple	6		4	Purple	B -
White	7		5	White	C
Yellow	8		6	Yellow	C -
Orange	21	( Red )	7	Orange	VCMD
Light Blue	20		8	Light Blue	GND
Grey	12		8	Grey	GND
White	23		+5V , +24V input		
Black	37		SERVO ON		

### SANYO servo motor setting value ( Voltage Command )

#### PY SERVO

MODE	PAGE	ABBREVIATE	NAME & ABOUT	STANDARD VALUE	SETTING VALUE
1	4	ENCR	Output pulse frequency division ratio	1/ 1	1/ 3
1	14	VCMS	Analog speed command maximum output	500	200
2	1	FUNC0	SW0 (Bit 5 = 1)	00000000	00100000

## Appendix 8 : Mitsubishi Servo Machinery Connection

### HUST CPU LINE & MITSUBISHI J2-S CONNECTION ( Voltage Command )

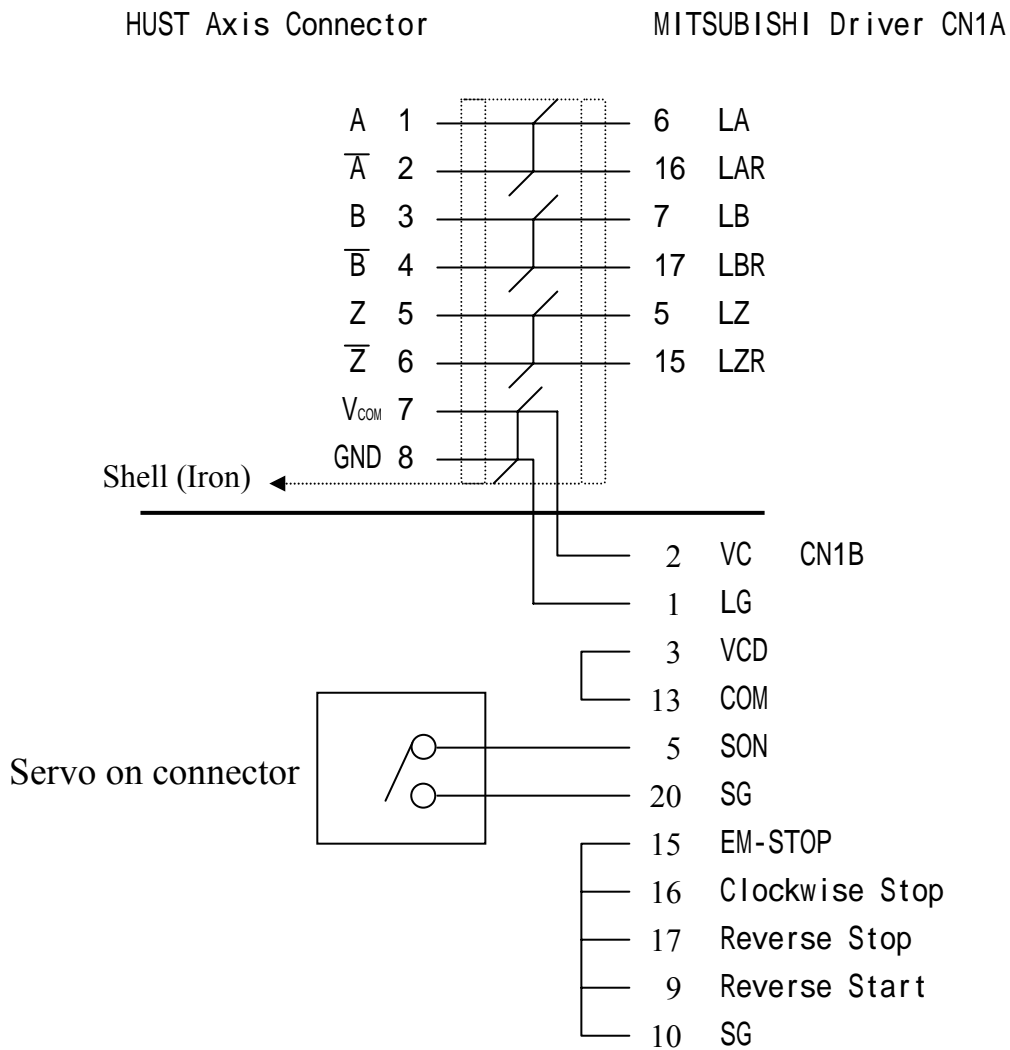

Driver MCM setting:

P00 = 0002

P27 = 8000 PULSE ( Feed back per round )

## Appendix 9 : Servo Motor And MPG Connection

Connect servo drivers to X-AXIS, Y-AXIS, and Z-AXIS connectors and connect MPG hand-wheel to MPG connector as shown below. Note that the connections may vary depending on the type of servo motor and the MPG hand-wheel that customers use. Please consult manufacturer's manual before connection.

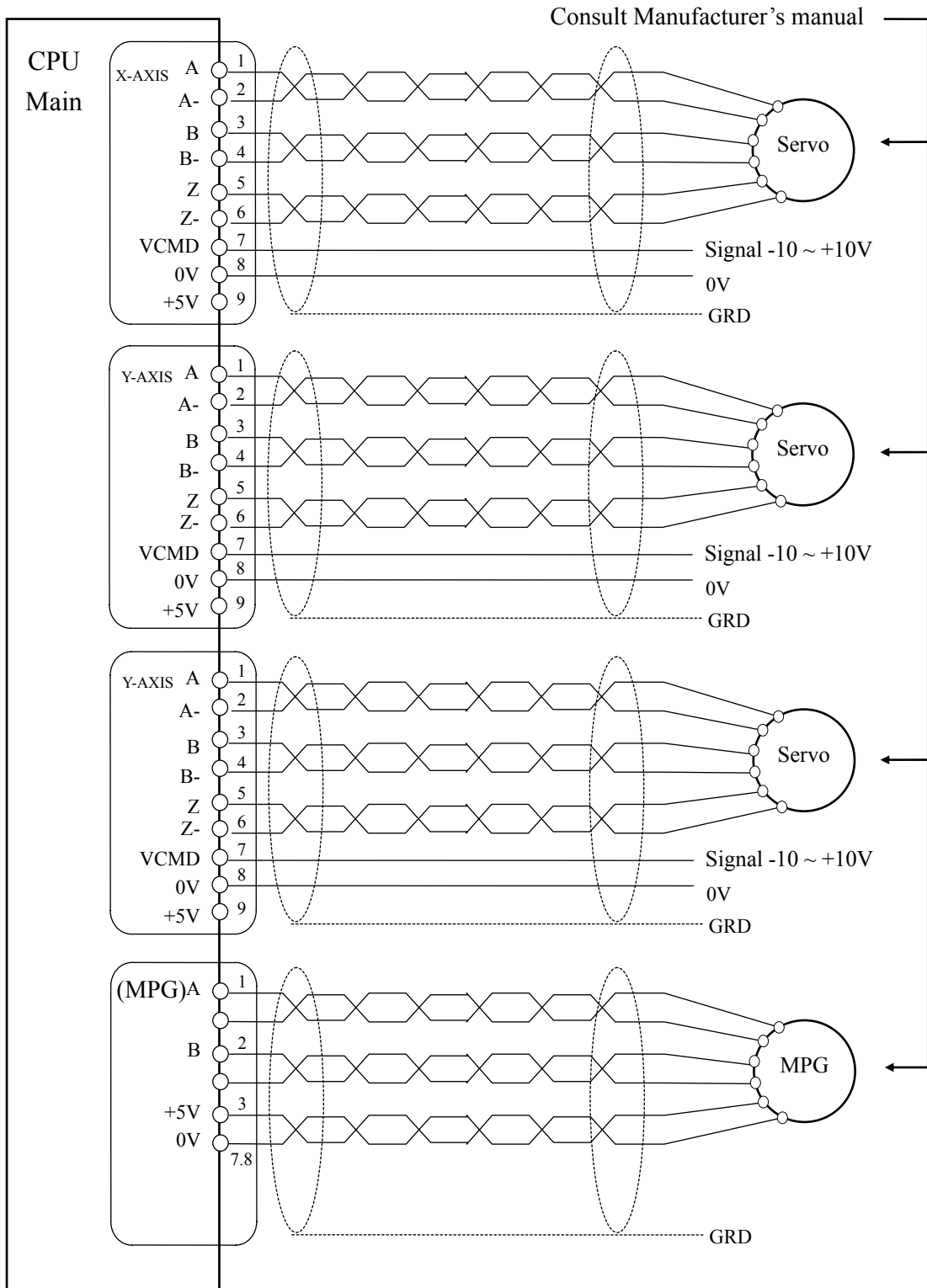

## Appendix 10 : Install Manual

1. Test the I/O signal.
2. Adjust the parameter of servo motor and controller.
3. Check the direction of servo motor:  
The Y (D) axis direction must depend on the machine.  
Illustration is below :

### EX 1. O-TYPE (Open Type)

Y – opening default  
= 450

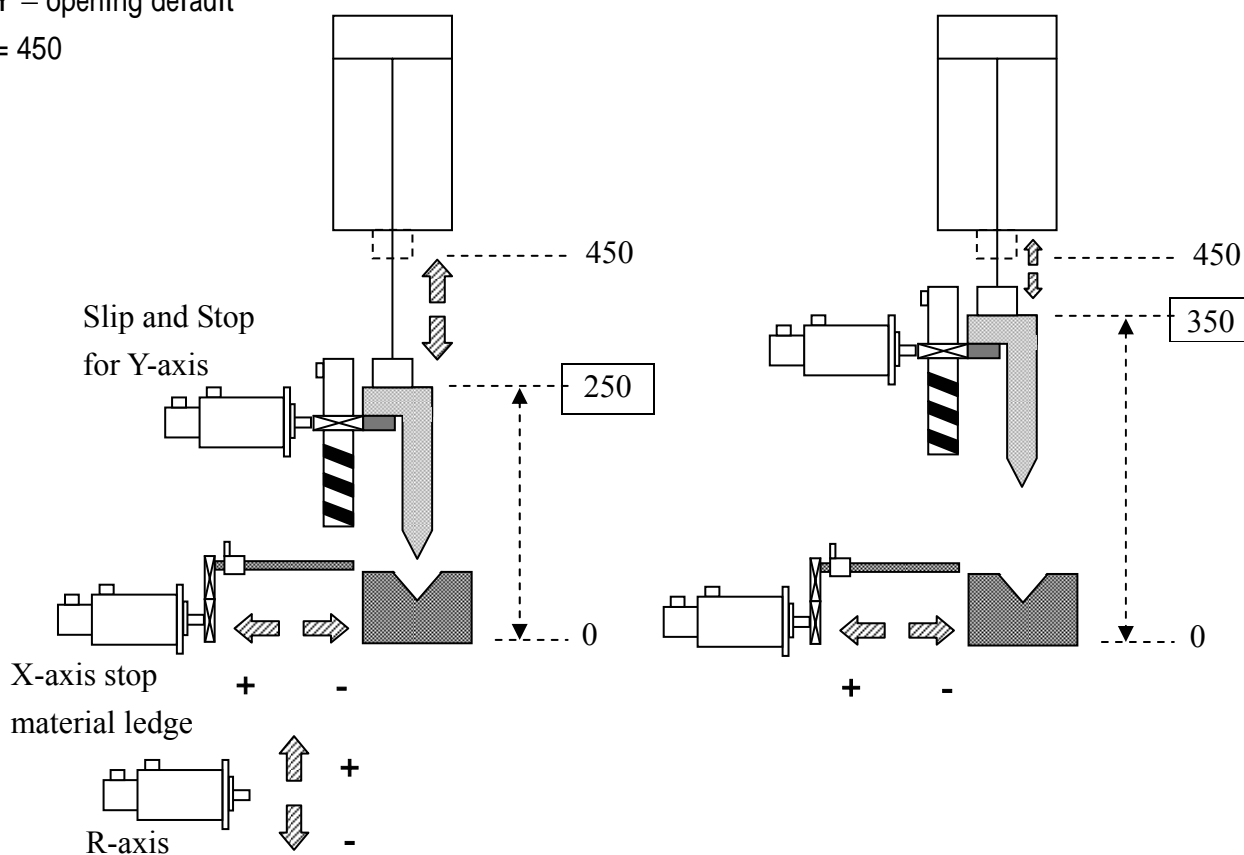

The coordinate displayed by controller is the actual position when machine opening.

## EX 2. D-TYPE (Distance Type)

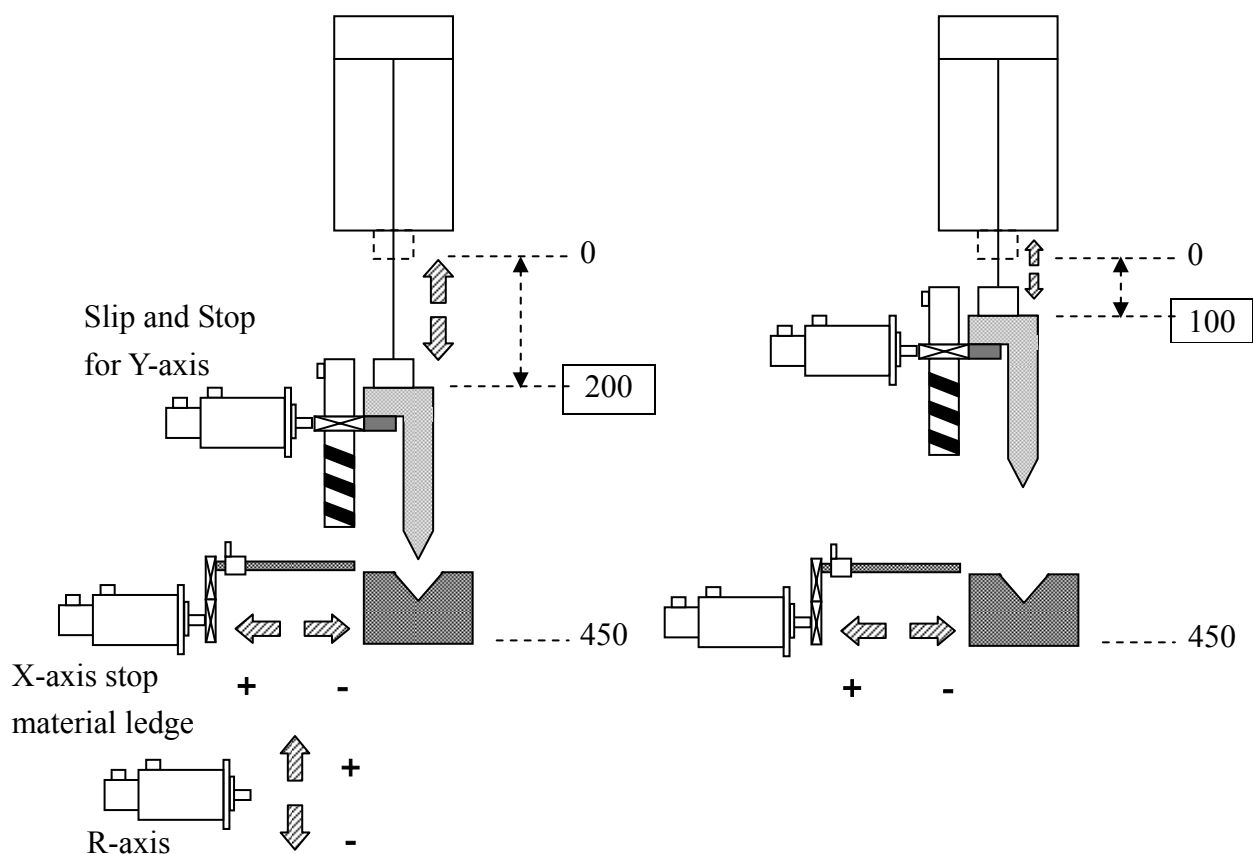

The coordinate displayed by controller is the position from the origin point.

## 4. HOME operation

(1) HOME operation of X-axis and Z-axis.

(2) JOG mode, move the Y axis to machine coordinate, then Y set 0.

The way of the Y SET 0 is below :

- Parameter page 4.
- Lock the function key on the mcm page = 1
- Press the 『Reset』 key.
- Get in the Parameter page 4 again.
- Press the 『Y Set-0』 key 6 sec.

(3) After Y-axis going back to HOME , input the new **program position**. (HOME limit)

Parameter page 3 : D-axis HOME limit setting

The value is shut Height or MOPM.

MOPM : Machine Opening Position Module

5. Test if each axis' resolution is correct :
  - (1) Move the X-axis some distance and measure it if correct ; If not, please change the resolution.
  - (2) Y-axis is mainly for checking the MOPM(Machine Opening Position Module). After traveling some distance, check the value of MOPM if the same with Y-axis' coordinate. If not, please change the resolution.

*If there is no MOPM, please measure the act. ( Step 3 EX 1 )*

6. Revise the X(L)-axis coordinate :
  - (1) Move the X-axis to the proper position for measuring easily.
  - (2) In the condition that Basic parameter cipher code has been solved, there will be the 『correct』 function key.
  - (3) Get in the correction displaying page and input actual measuring value.
  - (4) Press 『ENTER』 key twice quickly. The X-axis coordinate will change to the default value automatically.

7. Check if the setting of MOPM(Machine Opening Position Module) is correct :

**Way to ascertain the 『D-TYPE』 : Increase the value and the opening will getting small.**

**Consult the Step 3 EX 2.**

**The calculation of Y- opening default = 0 (Parameter page 4)**

When the Y(D)-axis has arrived at HOME, the MOPM value = 108.00 and the Y-Opening default setting = 400.000 (Parameter page 3)

Then let the UP-TOOL go down to the position of STOP POINT slowly. And measure the distance of machine opening.

$$400.000 - 108.000 = 292.000。$$

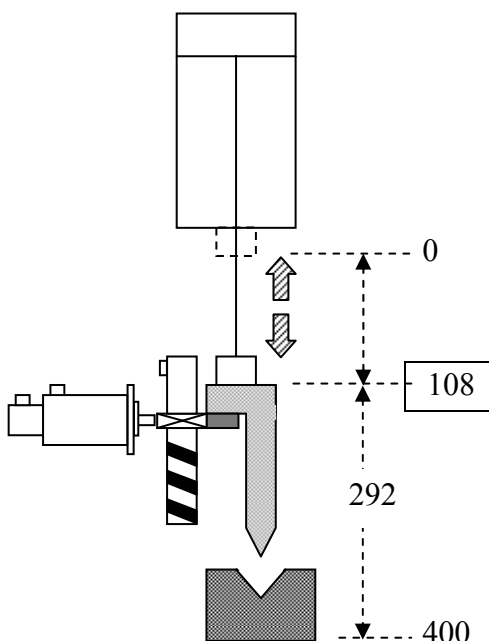

Way to ascertain the 『O-TYPE』 : Increase the value and the opening will getting big.

Consult the Step 3 EX 1.

The calculation of Y- opening default = 1 (Parameter page 4)

When the Y(D)-axis has arrived at HOME, move the STOP POINT to the position that it won't crash. Then the value of MOPM= 326.00.(For ex.)

Move the UP-TOOL to go down to the position of STOP POINT slowly. And measure the distance of machine opening = 326.000

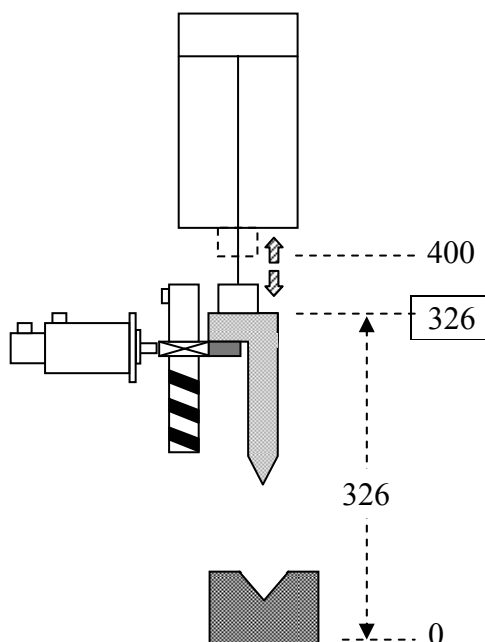

\*\* When the measuring value has some error, user can change the setting value of MOPM or set it in the 『D-axis adjust value』 of controller. (Parameter page 3)

EX 1.

MOPM = 326.00

Measure the distance of machine opening = 327.319

『D-axis adjust value』 = 1.319 (Parameter page 3)

EX 2.

MOPM = 326.00

Measure the distance of machine opening = 325.117

『D-axis adjust value』 = -0.883 (Parameter page 3)

8. Ascertain each parameter of controller below

- (1) D-axis adjust value. (Parameter page 3)
- (2) Y- Opening default setting. (Parameter page 3)
- (3) D-axis HOME limit setting. (Parameter page 3)

- (4) The calculation of Y- opening default. (Parameter page 4)
- (5) Input the value in the Edit、 FOLD and TYPE mode.
- (6) C = Empty
- (7) G = 0.000

9. Ask the machine factory to ascertain the 90 degree's position of Y(D)-axis and to record the position. When doing the bending test, the setting value of trough width is recommended as 6~8 times the piece thickness. (Fig 1)

If the machine factory can not sure the 90 degree's position.

- (1) Let the tool like Fig 2.
- (2) Record the MOPM position.

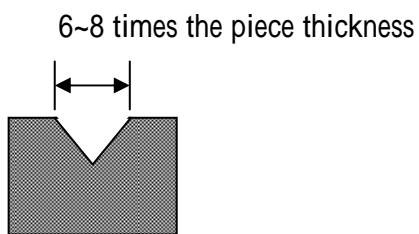

Fig 1

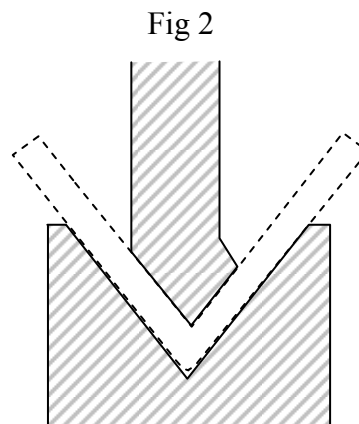
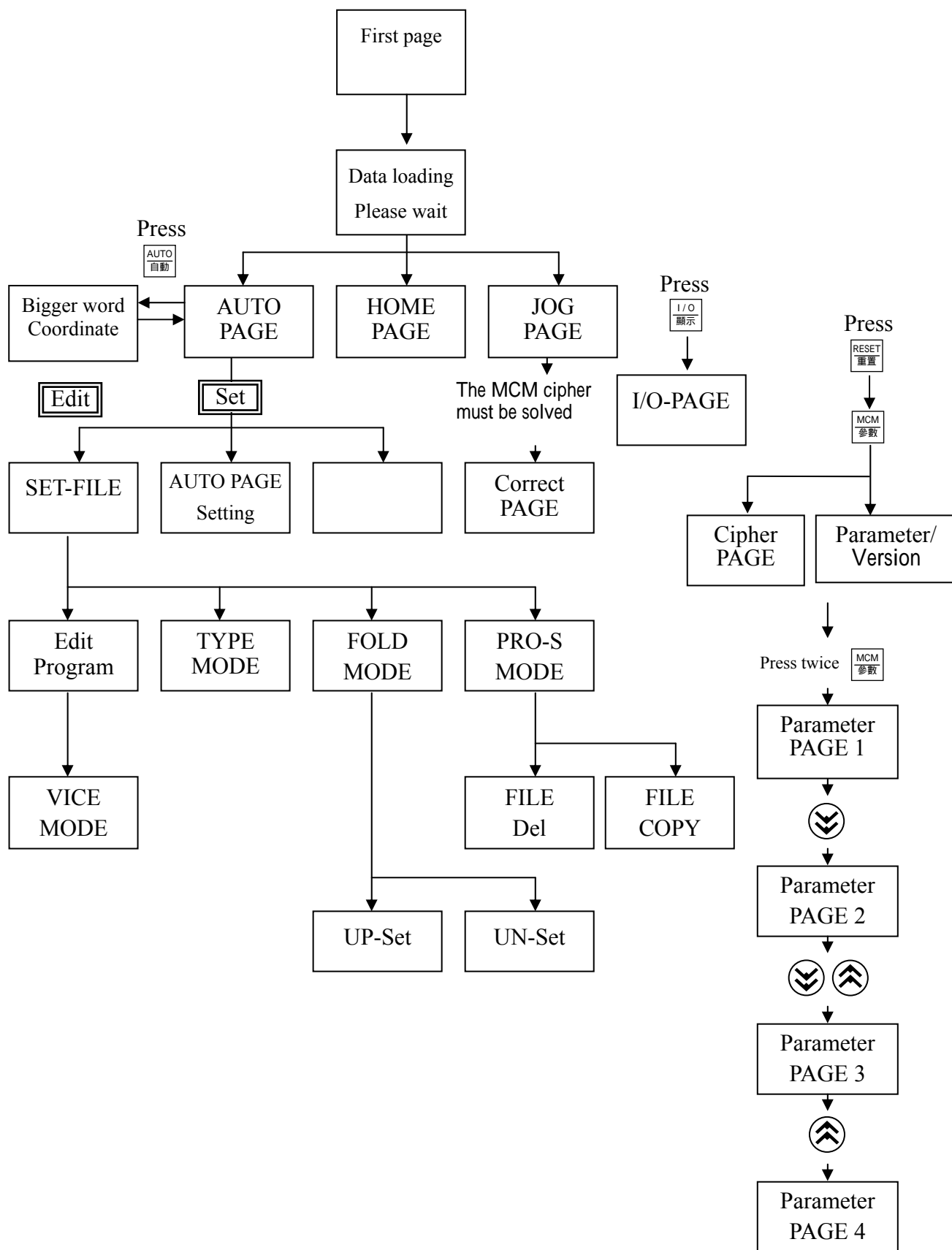

Fig 2

10. As editing simple program, it is major for testing 90 degree's. Then execute the program and observe if the controller location is close to the record value of 9<sup>th</sup>. If adjust the value of 'D-axis adjust value' directly, it can be done till the standard 90 degree being tested out. ; If it is not close to the record value of 9<sup>th</sup> , please ascertain the Y-axis' settings again and then test again.

11. After working hard so long, please remember to burn the parameters into the FlashRom and then download them as copy.

### H4B LCD flow-process diagram



## **Appendix 11 : ERROR MESSAGES**

---

### **ERROR-01** MCM Data Error or Battery Fail

Message: MCM parameter setting is incorrect or the backup battery has failed.

Recommended Remedy:

1. Check if MCM parameter setting data are correct. Or, execute LD MCM to reset the parameters.
2. If the controller has not been turned on for months, the data in the memory will be lost. The controller will show “BT1” message. In this case, change the battery.

### **ERROR-02** Servo Alarm or Return “Home” again

Message:

Servo position control (servo feedback) error. Possible causes are:

1. The voltage command from the controller is too fast for the motor to response.
2. The controller does not receive any feedback signal from the servo motor.

Recommended Remedy:

1. Check if the feed-rate "F" in the part program is too fast.
2. Check if the resolution settings of MCM parameters are correct. (Parameters Page 1)
3. Check if the worktable being overloaded, or any obstruction in the motor. Also check the servo system including the connections.

### **ERROR-10** RS232 Error.

Message: RS232 communication error.

Recommended Remedy:

1. Check the baud rate in MCM #168 if compatible with the one in PC.
2. Check the communication cable connection from PC to CNC controller.

### **ERROR-11** Program Memory Error

Message:

Error in program memory due possibly from lack of charge in battery or memory being overloaded.

Recommended Remedy:

1. Clear all programs.
2. Check battery for memory chip. If the controller has not been turned on for 3 months, the data in the memory will be lost. The controller will show “BT1” message. In this case, change the battery.

**ERROR-14** Axis Over-travel.

Message: The cutting tool traveled beyond the hardware limit.

Recommended Remedy:

Use MPG hand-wheel (or by hand) to manually move the tool in the X-axis within the operating range (or inside the hardware limit switch).

**ERROR-15** HOME GRID

Message: When servo motor searching the GRID signal, the distance exceeds the setting range

Recommended Remedy::

1. Check if the settings of  $\text{P}$  Parameter page 2 is larger than the distance servo motor turning one round  
EX :  
The distance of X-axis servo motor turning one round = 5.000 mm  
then  $\text{P}$  Parameter page 2 = 5.200
2. Check CPU connection.

**ERROR-18** End of File Not Found

Message: Error in the program ending or no program content.

Recommended Remedy:

**Contact the engineer.**

**ERROR-20** Software Over-travel

Message: The cutting tool has traveled beyond the bounding limit as set by the software.

Recommended Remedy:

Check the program or revise the settings in  $\text{P}$  Parameter page 1 for software travel limit.

**ERROR-22** Em-Stop, Home Again

Message: Controller is in emergency stop state.

Recommended Remedy:

Resolve the cause for emergency stop. Restore Emergency-STOP button and press RESET.

**ERROR-30.1** BATT.LOW

Message: The battery (BT1) for data storage is out of charge or service.

Recommended Remedy:

Replace the battery BT1 or power on for 5 hours.

**ERROR-31** None PLC

Message: There is no PLC ladder program in the memory.

Recommended Remedy:

**Contact the engineer.**

**ERROR-51**

Message:

The machine coordinate of X(L)-axis > The setting of software OT +.

Recommended Remedy:

Ascertain the value of Parameter page 1 『 Software OT +1 』 .

**ERROR-52**

Message:

The machine coordinate of X(L)-axis < The setting of software OT - .

Recommended Remedy:

Ascertain the value of Parameter page 1 『 Software OT - 1 』 .

**ERROR-53**

Message:

The machine coordinate of Y(D)-axis > The setting of software program-pos. OT +.

Recommended Remedy:

Ascertain the value of Parameter page 2 『 Software Program-Pos. OT + 』 .

**ERROR-54**

Message:

The machine coordinate of Y(D)-axis < The setting of software program-pos. OT - .

Recommended Remedy:

Ascertain the value of Parameter page 2 『 Software Program-Pos. OT - 』 .

**ERROR-55**

Message:

The machine coordinate of Z(R)-axis > The setting of software OT+.

Recommended Remedy:

Ascertain the value of Parameter page 1 『 Software OT+1 』 .

**ERROR-56**

Message:

The machine coordinate of Z(R)-axis < The setting of software OT - .

Recommended Remedy:

Ascertain the value of Parameter page 1 『 Software OT - 1 』 .